

HAFCO-WOODMASTER BP-255



Wood Band Saw

2 Blade Speeds - 400 & 800m/min



HAFCO-WOODMASTER Wood Band Saw BP-255



Front View



Rear View



Easy Access for Blade Change



Cast Iron Tilt Table to 45 Degrees



Tilt Table Adjustment



Ball Bearing Blade Guides



Cast Iron Table with T Slot



Sliding Rip Fence with High and Low Height Extrusion

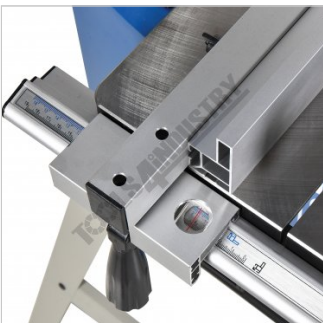

Fence with Quick Action Lock and Sight Glass



Blade Support Adjustment



Mitre Guide



Blade Guard Micro Switch



Work Light



Safety Magnetic Switch and Light Switch



100mm Dust Port and Motor



Blade Tension and Tracking Adjustments

HAFCO-WOODMASTER Wood Band Saw BP-255

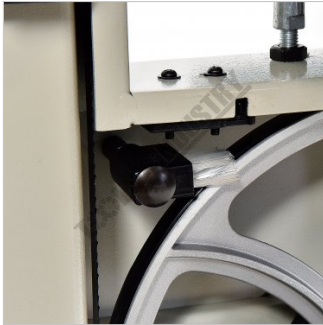

Wheel Cleaning Brush



Belt Speed Diagram



Dust collection Tray



Push Stick and Tools



Shown with Optional Circle Cutting Attachment

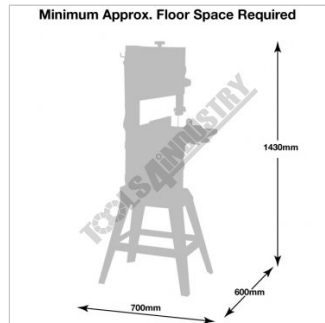

Minimum Floor Space Required

Description

The BP-255 is a compact entry level bandsaw with many features that would suit the home woodworker craft workshop.

This bandsaw has a welded steel frame designed to keep your machine from twisting whilst cutting at 245 x 145mm capacity. It has a generously 360 x 320mm cast iron table with an aluminium rip fence and mitre guide to help you cut straight or angles to the required size. The table mounting trunnions are adjustable to get your table to tilt from 90 to 45 degrees and has a quick action locking lever. This machine also has its own LED light that is mounted to a flexible arm so the light can be adjusted direct on the cutting line no matter what timber size you are cutting.

The BP-255 bandsaw though small in structure but quality is still evident as it includes ball bearing blade guides to ensure smooth blade rotation & accuracy. These provide optimum blade support and are almost impossible to wear out. Once set-up, they stay set unless you change the width of the blade. For your convenience, a rack and pinion system adjusts the upper blade guide height to suit your timber.

The dust extraction port located at rear of machine will remove most of your internal dust once connect to your dust extractor; and whatever the extractor does not collect the removable tray built into the stand will collect the rest. The 2-speed pulley system rotates at 400 or 800m/min and is driven by a nicely matched 375W / 0.5hp 240V motor

HAFCO-WOODMASTER Wood Band Saw BP-255

Features

- 375W / 1/2 hp 240V induction motor
- Ball bearing blade guides to ensure smooth operation
- Safety magnetic switch with dust cover and emergency stop
- Hinged blade guards with safety micro-switches
- LED work light on flexible arm
- Cast iron table tilts 0-45° with mitre guide
- Geared rack on cutting height adjustment
- 2 blade speeds - 400 & 800m/min
- Aluminium rip fence with quick action lock
- Hinged top & bottom blade guard doors enables quick blade replacement
- Steel stand with slide dust compartment drawer
- 100mm dust collector port

Includes

- Push Stick
- Allen Keys
- Spanner

Specifications

ORDER CODE	W950
MODEL	BP-255
Wheel Diameter (Ø) (mm)	255
Throat Capacity (mm)	245
Height Capacity (mm)	152
Table Size (mm)	360 x 320
Frame Type	Steel
Motor Power (kW / hp)	0.375 / 0.5
Voltage / Amperage (V / amp)	240 / 10
Blade Code (Suits)	W950A, W950B, W950F
Blade Size (L x W x T) (mm)	1826 x 12.5 x 0.65
Floor Space (W x D x H) (mm)	750 x 650 x 1430
Nett Weight (kg)	38