

HAFCO-WOODMASTER SP-300



Spindle Moulder

710 x 640mm Table Size



HAFCO-WOODMASTER Spindle Moulder SP-300



Top View



Sliding Table with Mitre Guide and Top Clamp



Spindle Adjustment Controls

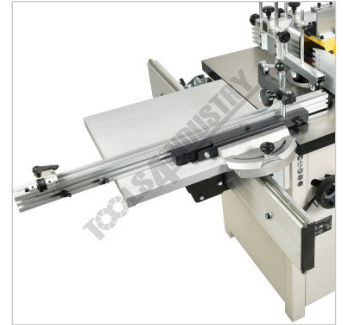

Includes Sliding Table



Includes Mitre Guide



30mm Cutter Head



Tilting Arbor to 30 Degrees



Sanding Sleeve Attachment



Cutter Guard with Dust Chute

Features

- Ø30mm spindle arbor diameter
- 100mm up & down spindle travel
- 200mm total spindle length
- 900mm table work height
- Tilting arbor to -5° ~ $+30^{\circ}$ for various profiles
- 710 x 640mm cast iron work table
- Cast cutter guard with Ø100mm dust collector port
- Rise and fall adjustment and spindle lock for easy cutter change
- 4 spindle speeds with FWD/REV 1800, 3000, 6000, 9000rpm
- 2.8kW / 3.75hp 15Amp 240V motor

HAFCO-WOODMASTER Spindle Moulder SP-300**Includes**

- Sliding table with mitre guide
- Cutter guard with dust chute
- Ø74mm sanding sleeve attachment

Specifications

ORDER CODE	W640
MODEL	SP-300
Table Size (mm)	710 x 640
Spindle Arbour Speeds (rpm)	1800, 3000, 6000, 9000
Spindle Arbour Diameter (mm)	Ø30
Spindle Arbour Travel (mm)	100
Tilting Spindle Arbour (Deg.)	-5° ~ +30°
Table Height (mm)	900
Table Opening (mm)	Ø200
Motor Power (kW / hp)	2.8 / 3.75
Voltage / Amperage (V / amp)	240 / 15
Floor Space (W x D x H) (mm)	1230 x 1500 x 1300
Nett Weight (kg)	221