

HAFCO DCK-100W



Wall Mounted Wood Dust Extraction Accessory Kit

Ø100mm (4")



HAFCO Wall Mounted Wood Dust Extraction Accessory Kit DCK-100W

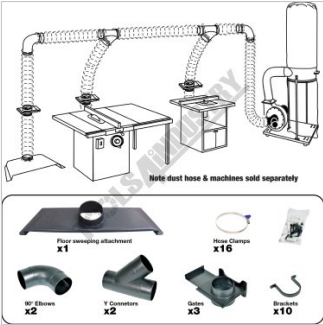

Shown SetUp



1 x Floor Sweeping Attachment



2 x 90 Degree Elbows Top View



2 x Y Connectors Top View



3 x Wall Mount Blast Gates Open



10 x Tube Hanging Brackets Top View



16 x Hose Clamps to Suit 100mm Hose



Fixing Accessories

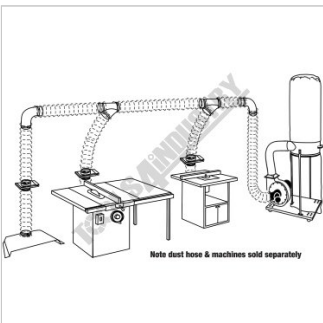

Shown with Optional Dust Hose and Accessories

Description

This Ø100mm wall mounted dust extraction accessory kit is the ideal solution to getting your dust collection hose off the floor.

All range of components are included to connect up to 2 machines to a dust extractor. Ø100mm hose is sold separately or simply reuse your own!

HAFCO Wall Mounted Wood Dust Extraction Accessory Kit DCK-100W

Includes

- 2 x 100mm 90° elbows
 - 2 x 100mm "Y" connectors
 - 3 x 100mm wall mount blast gates
 - 1 x Floor sweeping attachment
 - 10 x Wall mounting brackets and mounting hardware
 - 16 x Hose clamps to suit Ø100mm hose
- Please Note:
- We strongly recommend that you "Earth" this ducting kit to each piece of equipment and the dust collector itself to minimise the risk of static build-up that can result in fire.

Specifications

ORDER CODE	W3445
MODEL	DCK-100W
Type	Wall Mounted Dust Extraction Accessory Kit
Application	Timber
Size	Ø100mm Attachments
Suits	All Wood Dust Collectors
Nett Weight (kg)	12.5