

TOOLMASTER

Modular Machine Vice

152mm Jaw Width

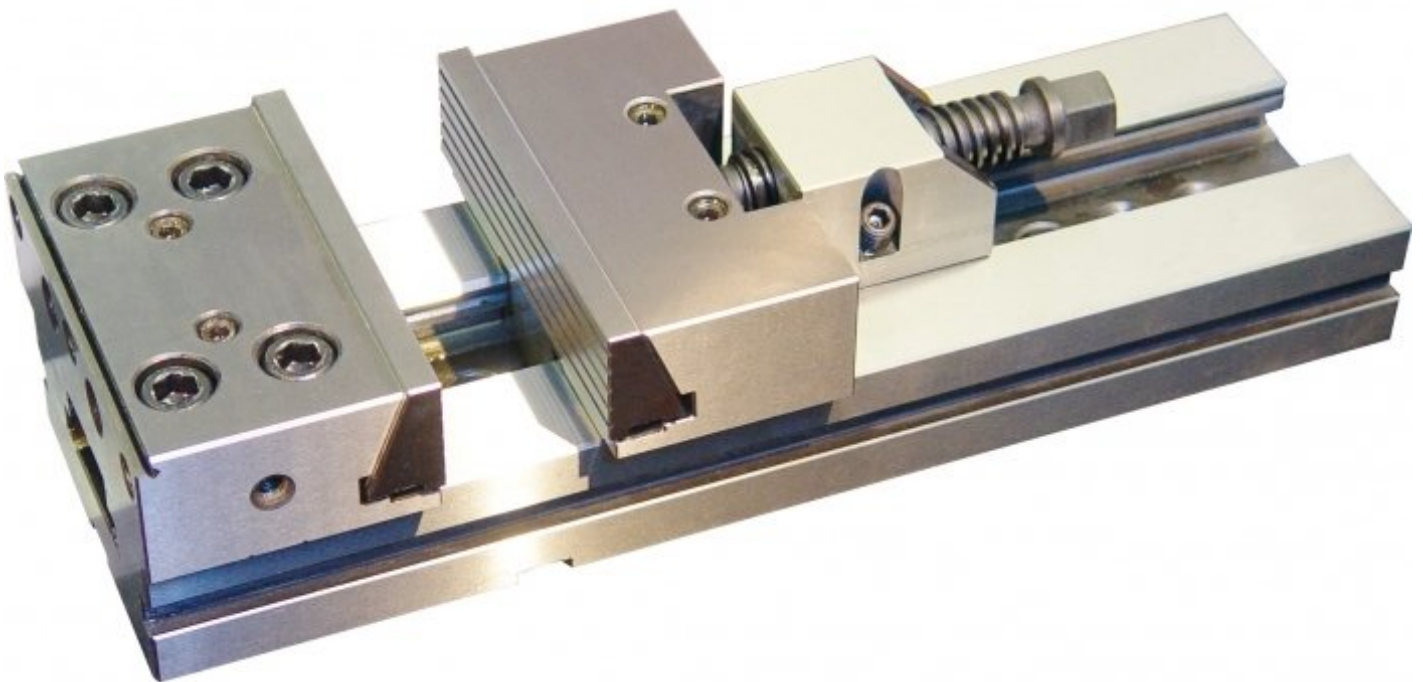

TOOLMASTER Modular Machine Vice

Description

Toolmaster vices are manufactured under rigid quality control. All Toolmaster vices are interchangeable and can be used as matched pairs.

Features

- Hardened and ground steel to HRC60, with high precision
- Keyways are 16mm H7 and are toleranced giving perfect alignment and reducing set up time
- Space saving design allows for maximum use of clamping area

Specifications

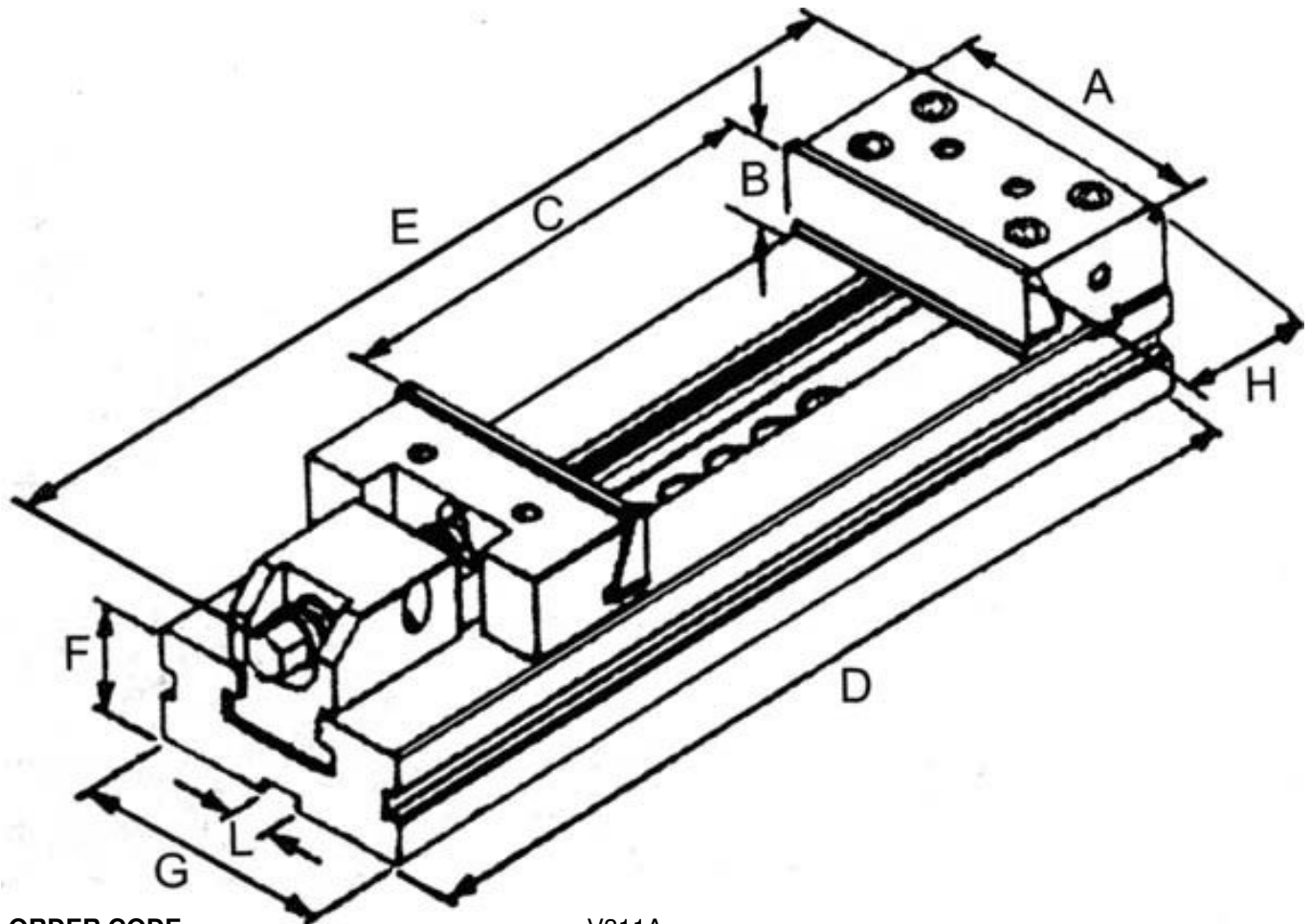

ORDER CODE	V311A
A - Jaw Width (mm)	152
C - Jaw Opening (mm)	300
B - Jaw Height (mm)	50
D (mm)	520
E (mm)	600
F (mm)	50
G (mm)	125
H (mm)	90
Nett Weight (kg)	37

TOOLMASTER Modular Machine Vice