

HAFCO TC-800



6 Drawer - Industrial Tooling Cabinet

723 x 653 x 800mm



HAFCO 6 Drawer - Industrial Tooling Cabinet TC-800



Top Drawer with Plastic Buckets



Drawers with Steel Dividers



Plastic Bucket Drawers



Heavy Duty Drawers



Drawer Locking Mechanism



Drawer Lock Bracket



Drawer in Lock Position



Drawer in Unlock Position



Heavy Duty Drawer Slides



Drawers with Safety Lock



Drawer Ball Bearing Arms

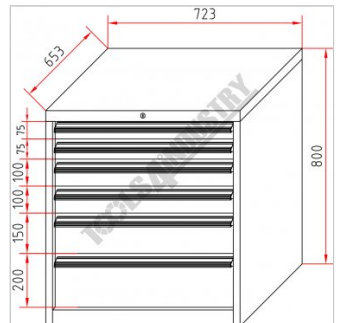

Diagram

Features

- Heavy duty tooling cabinets, ideal for industrial applications and serious workshops
- The sliding drawers are a welded strengthened single rail design coupled with high quality mechanical bearings for long lasting smooth operation
- Each drawer is rated at 100kg load capacity with 97% drawer access and a total of 600kg maximum load capacity
- Single Key lock design for safe storage. Each drawer has a mechanical safety lock which allows one drawer to be opened at a time, preventing the cabinet to tip over
- All top drawers include a series of different size plastic boxes for those small items, all other drawers come with adjustable steel dividers
- The optional steel frame backing panel with rubber protective base cover is great to rest tooling and precious parts on top of the cabinet

HAFCO 6 Drawer - Industrial Tooling Cabinet TC-800

Includes

- Top Drawer - 75mm high with moveable plastic division boxes
- Drawer 2 - 75mm high with moveable steel dividers 4x3 layout
- Drawer 3 & 4 - 100mm high with moveable steel dividers 4x3 layout
- Drawer 5 - 150mm high with moveable steel dividers 4x3 layout
- Drawer 6 - 200mm high with moveable steel dividers 4x3 layout

Specifications

ORDER CODE	T767
MODEL	TC-800
Number of Drawers (No.)	6
Drawer Load Capacity (kg)	100
Maximum Total Load Capacity (kg)	600
Includes Backing Panel	~
Dimensions (W x D x H) (mm)	723 x 653 x 800
Nett Weight (kg)	102