

TOOLMASTER T3-MT3



Reversible Tapping Chuck - Adjustable Clutch

Include 3MT & 4MT Arbours



TOOLMASTER Reversible Tapping Chuck - Adjustable Clutch T3-MT3



Full Kit



Shown With Tapper



Blow Mold Case

Features

- Pre-select torque drive to prevent tap breakage and allow for blind hole tapping
- Tension and compression feature compensates between rate of feed applied and thread pitch
- Suitable for right and left hand, vertical and horizontal tapping
- Fast tap reversal. Re-entry cushioning eliminates cross threading

- Clutch Torque Setting:
 - 1 - 5 Nm
 - 2 - 20 Nm
 - 3 - 50 Nm
 - 4 - 75 Nm

Includes

- MT3 & MT4 x JT6 arbors
- 2 x Collet chuck spanners
- 2 x Rubber flex collets
- 2 x allen keys

Specifications

TOOLMASTER Reversible Tapping Chuck - Adjustable Clutch T3-MT3

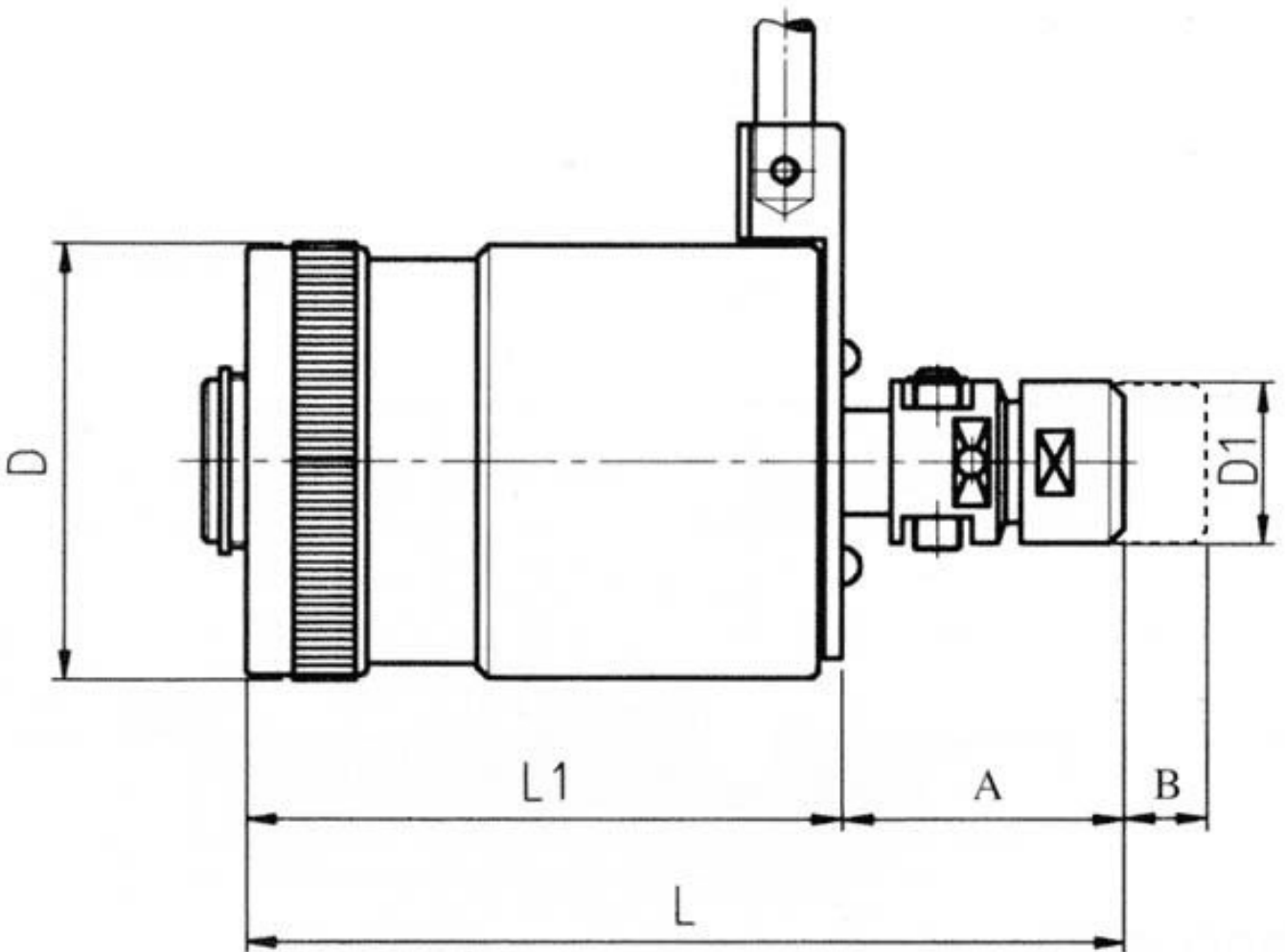

TOOLMASTER Reversible Tapping Chuck - Adjustable Clutch T3-MT3

ORDER CODE

TOOLMASTER Reversible Tapping Chuck - Adjustable Clutch T3-MT3

T004

MODEL	T3-MT3
Arbor Mount	JT6
Taper (MT)	3 & 4
Tapping Range (mm)	5 - 12
Tapping Shank Size (mm)	3.5 - 10
D (mm)	75
D1 (mm)	28
L (mm)	150
L1 (mm)	105
A (mm)	45
B (mm)	12
Nett Weight (kg)	4.2