

RECORD POWER BS400



Wood Band Saw



RECORD POWER Wood Band Saw BS400



Industrial Style Fence



Cast Iron Band Wheels



Doors Open

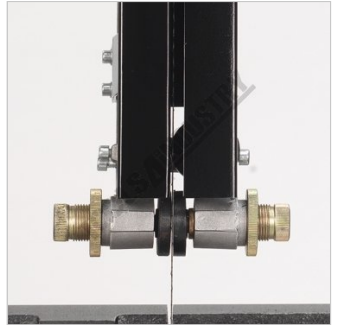

4 Accurate and Easy to Use Blade Guides



Large 535 x 480mm Cast Iron Table



Cam Action Tensioner

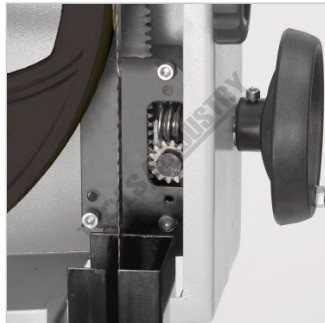

Toolpost Support



Trunnion

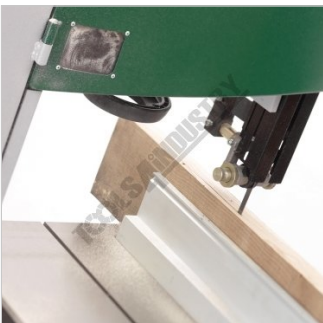

Action 1



Action 2

Description

The Record Power BS400 bandsaw offers high quality, industrial features and large capacities to the mid range bandsaw market. This machine brings affordable solid performance and reliability within reach of the discerning woodworker.

Like all bandsaws in the range, a solid cast iron table provides unrivalled stability and solidity. An industrial style cast trunnion supports the table and allows it to be tilted one-handed on a rack and pinion. Dynamically balanced cast iron bandwheels ensure superior strength and reduced vibration - a feature not usually found on other machines at this level. The 2hp motor and 305mm depth of cut mean this machine can cope easily with large timbers yet is also equally capable of fine, precise cuts and veneers.

The exceptional value for money this machine offers is difficult to appreciate without seeing the machine first hand. If you are in the market for a high specification mid-range bandsaw, be sure to seek out the BS400 at your nearest dealer or at one of our many shows and compare it to other bandsaws on the market.

RECORD POWER Wood Band Saw BS400

Features

- Cast Iron Band Wheels - These are dynamically balanced and provide a flywheel effect for improved cutting performance. Rubber tyres are precision ground for easy blade fitting and smooth drive.
- Industrial Startrite Style Fence - This high quality fence features a heavy extrusion mounted on a cast iron base, which moves along a solid steel bar. This provides exceptional strength and accuracy and is easily locked with the brass screw and handle.
- Large Cast Iron Table - This provides a strong and steady work area to support large workpieces. Finely ground finish enables effortless movement of the timber.
- Cam Action Tensioner - With the flick of a handle the tension is released on the blade enabling quick easy changing, but more importantly, when reset, the previous tension is automatically applied to the new blade. This makes blade changing a much simpler task and allows tension to be taken off the blade when not in use.
- Toolpost - The toolpost features jacking screws and rack and pinion rise and fall for easy adjustment.
- Microswitches - Are fitted top and bottom for added safety, cutting power to the machine when the doors are open.
- Motor - Quiet and powerful 2 hp output induction motor will handle a wide variety of projects with ease.
- Accurate and Easy to Use Blade Guides - Blade guides need accurately setting if they are to be of any use – so easy access and adjustment are a must. Our guides, similar to those found on industrial machines, give good quality adjustment with minimal need for tools.
- Substantial Trunnion - Solid double trunnion table mount for rigid table support featuring one handed rack and pinion table tilt for ease of use and accuracy. Mounted on top of band wheel box with jacking screws for easy adjustment.
- Bandsaw Masterclass DVD Included - Presented by Alan Holtham, this indispensable DVD gives a thorough and comprehensive introduction to bandsaw use, setup, maintenance and blade choice.
- Table Height from Floor: 900mm
- Blade Speeds: 820 & 420 M/Minute
- Extraction Port Diameter: Ø100mm
- Size: L630 x W850 x H1800mm

Includes

- Mitre guide
- Heavy Duty Rip fence

Specifications

ORDER CODE	R823
MODEL	BS400
Wheel Diameter (Ø) (mm)	~
Throat Capacity (mm)	416
Height Capacity (mm)	305
Table Size (mm)	535 x 480
Frame Type	Steel
Motor Power (kW / hp)	1.5 / 2
Voltage / Amperage (V / amp)	240 / 10
Blade Code (Suits)	W433A, W433B
Blade Size (L x W x T) (mm)	3378 x 16 x 0.65
Floor Space (W x D x H) (mm)	~
Nett Weight (kg)	140