

**MEASUMAX 33-234**

**Gear Tooth Vernier Caliper**

**1-26 module**



**MeasumaX**

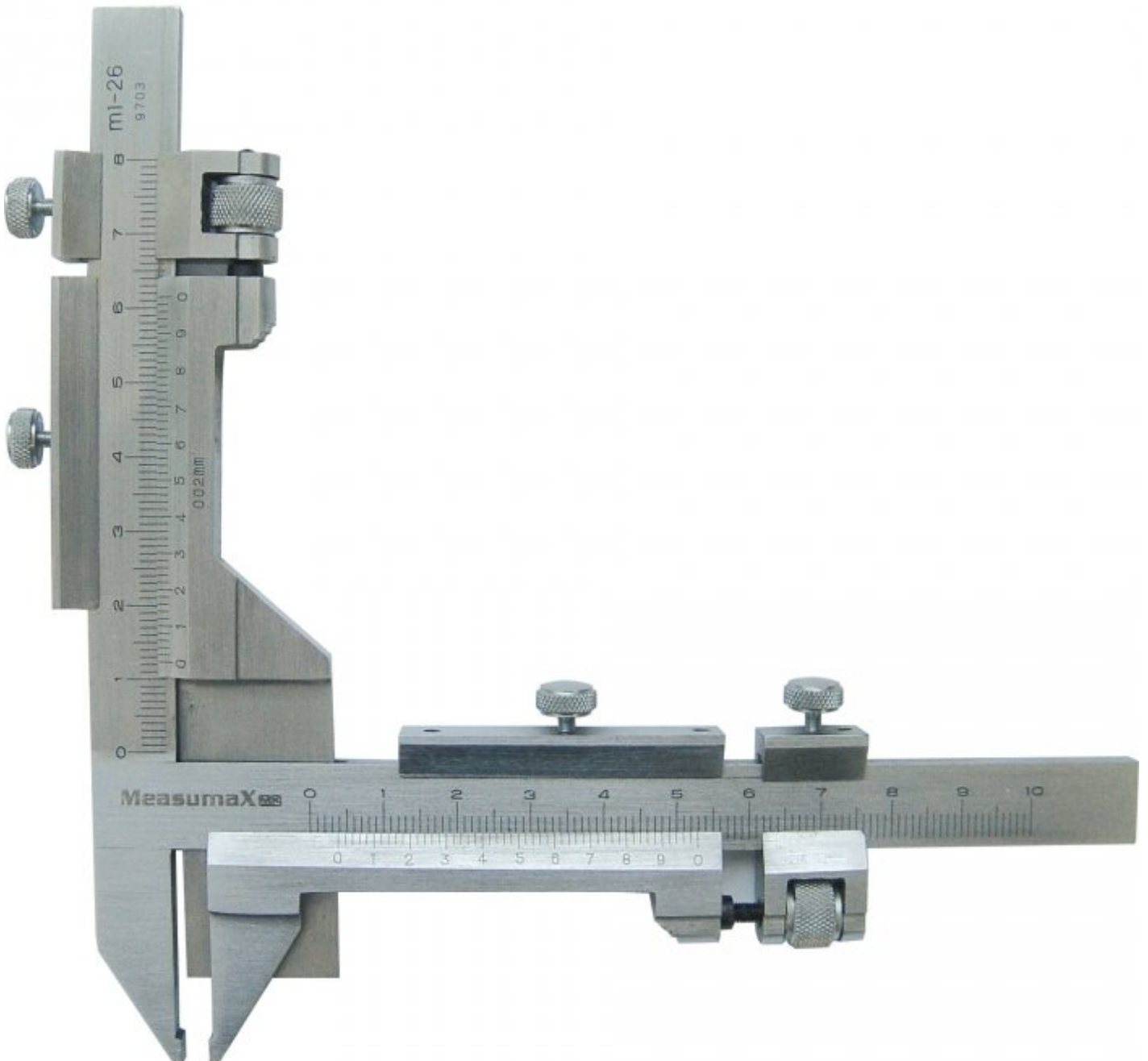

## MEASUMAX Gear Tooth Vernier Caliper 33-234

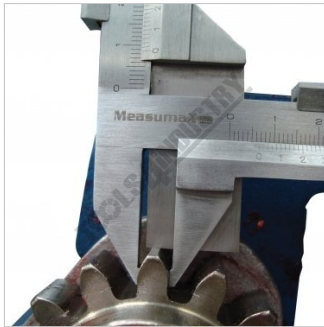

Shown measuring gear



Shown measuring gear

### Features

- One of the benefits using a caliper is that the gear does not have to be removed from the machine
- The caliper consists of two adjustable verniers, that reference two dimensions on the gear and provide a measurement
- Vertical scale: Measures the depth of the teeth from the top of the pitch line
- Horizontal Scale: This is used to measure the Chordal Thickness of the gear tooth

### Specifications

<b>ORDER CODE</b>	Q234
<b>Range</b>	1 - 26 Module
<b>Graduations (mm)</b>	0.02
<b>Accuracy (mm)</b>	±0.02