

HAFCO



Rivet Nut Inserts - M10 x 1.5mm

Steel - Zinc Plated



HAFCO Rivet Nut Inserts - M10 x 1.5mm



Packaging Front



Packaging Rear Side

Description

Suits ATR-10RN Air Operated or RNB40 Twin Handle Nut Riveters

Features

- Steel - Zinc Coated
- Fast & easy installation from one side
- Adds a threaded nut to thin sheet metal
- Knurled section under nut head for anti-rotation
- Easy to install

Includes

- 50 x Rivet Nut Inserts - M10 x 1.5mm

Specifications

HAFCO Rivet Nut Inserts - M10 x 1.5mm

NUT INSERT

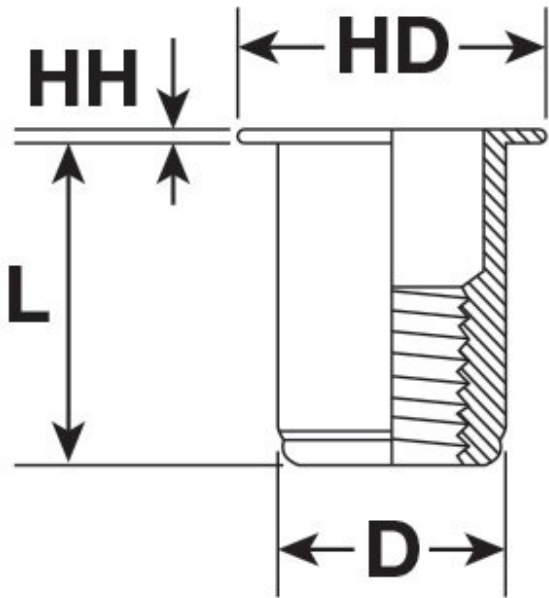

UNINSTALLED

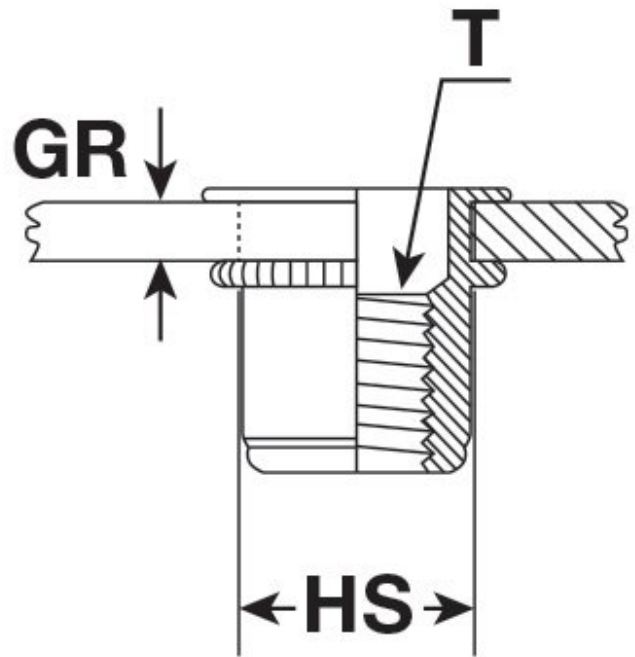

INSTALLED

HAFCO Rivet Nut Inserts - M10 x 1.5mm

ORDER CODE

HAFCO Rivet Nut Inserts - M10 x 1.5mm

N010

MODEL	~
Type	Rivet Nut Inserts
Nut Insert Material (Type)	Steel - Zinc Coated
Quantity in Pack	50
Rivet Nut Inserts Range (Metric)	~
Blind Rivets (mm)	~
Thread Size (T) (Metric)	M10 x 1.5
Thread Length (TL) (Metric)	~
Length (L) (mm)	18.5
Head Height (HH) (mm)	1.5
Head Diameter (HD) (mm)	17.15
Diameter (D) (mm)	12.9
Hole Size (HS) (mm)	13
Grip Range (GR) (mm)	1.00 - 4.00
Torque to Turn (Kgf.cm)	400