

HAFCO-METALMASTER HMA-4105

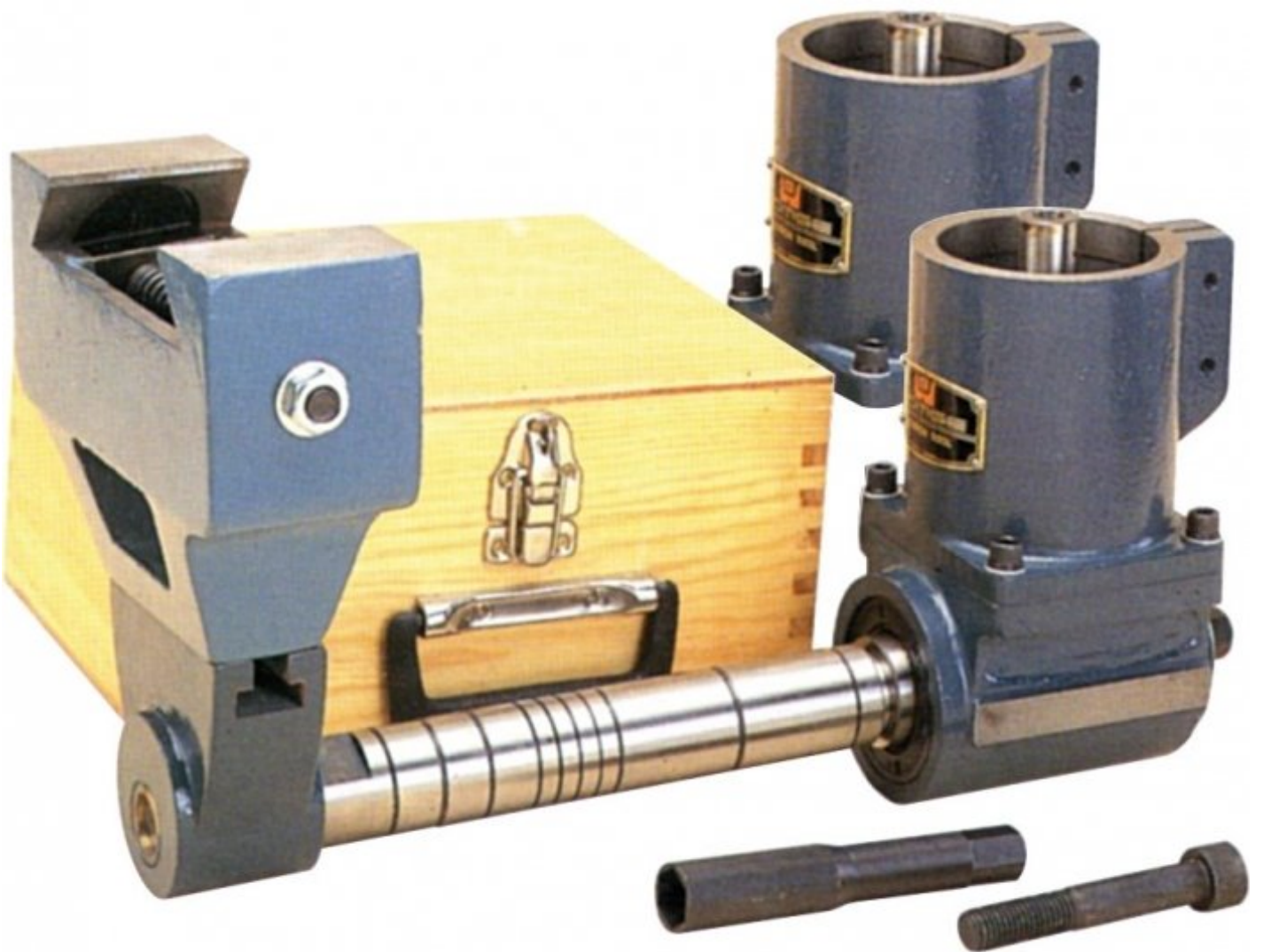

NT40 Horizontal Milling Attachment

Suits Ø105 & 86mm Quills



HAFCO-METALMASTER NT40 Horizontal Milling Attachment HMA-4105

Description

Manufactured in Taiwan

Used on vertical milling machine where horizontal work is required.
 Designed to simplify right angle work without the need for special tooling or complex fixtures.

Note! If using with an air powered drawbar the drive motor of the drawbar needs to be removed as the quill is lowered so that the horizontal attachment can be secured. As the quill is lowered the air drawbar is dis-engaged and cannot be used. For this application use a standard drawbar.

Features

- Arbor support suits dovetail widths of 140-170mm
- Supplied in deluxe wooden case
- Arbor Ø1" x 12" in length

Specifications

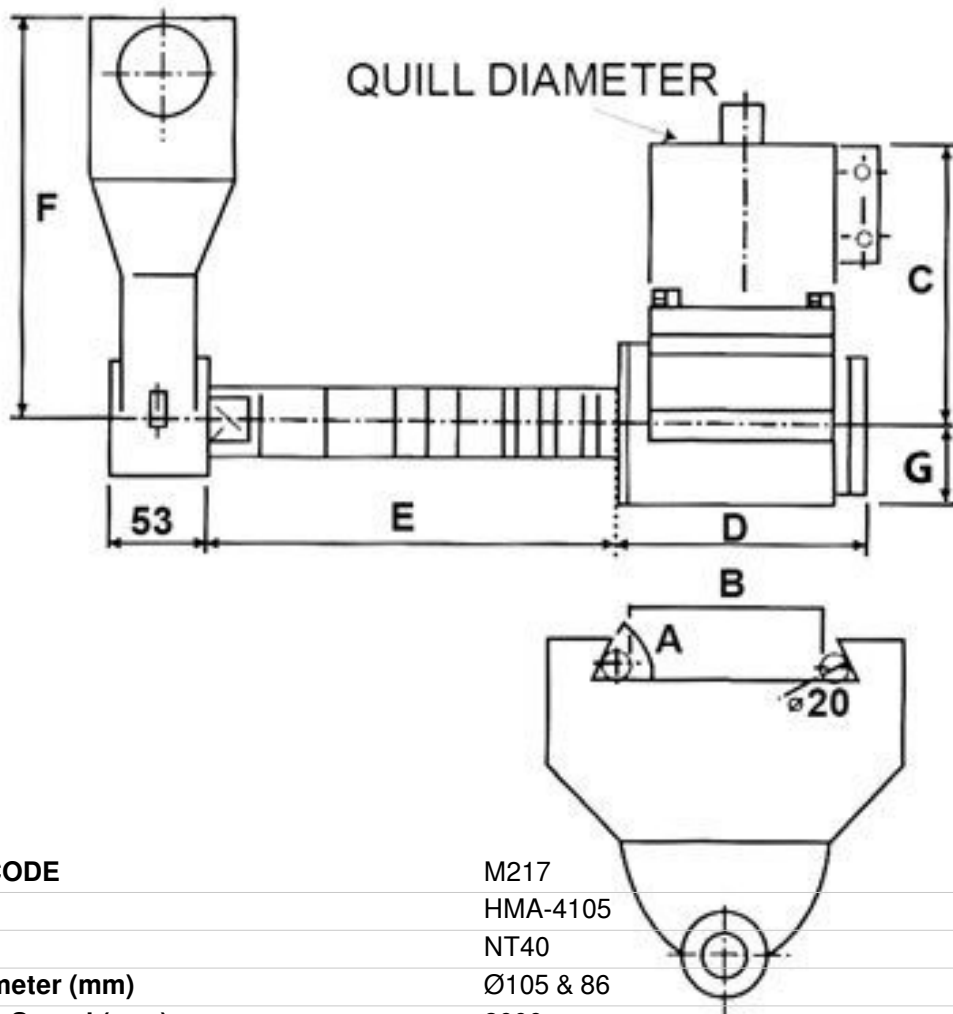

ORDER CODE	M217
MODEL	HMA-4105
Taper	NT40
Quill Diameter (mm)	Ø105 & 86
Maximum Speed (rpm)	2000
A (deg)	50°

HAFCO-METALMASTER NT40 Horizontal Milling Attachment HMA-4105

B (mm)	140 - 170
C (mm)	181
D (mm)	181
E (mm)	270
F (mm)	230
G (mm)	45
Nett Weight (kg)	34