

TOOLMASTER

NT40-NT30 Milling Adaptor



TOOLMASTER NT40-NT30 Milling Adaptor

Description

Precision reducing adaptor for NT40 to NT30

Features

- External and Internal taper precision ground
- Please Note:
 - Requires a M12 drawbar to be made long enough to reach NT30 holder
 - Not recommended for use on machines with air powered drawbar

Specifications

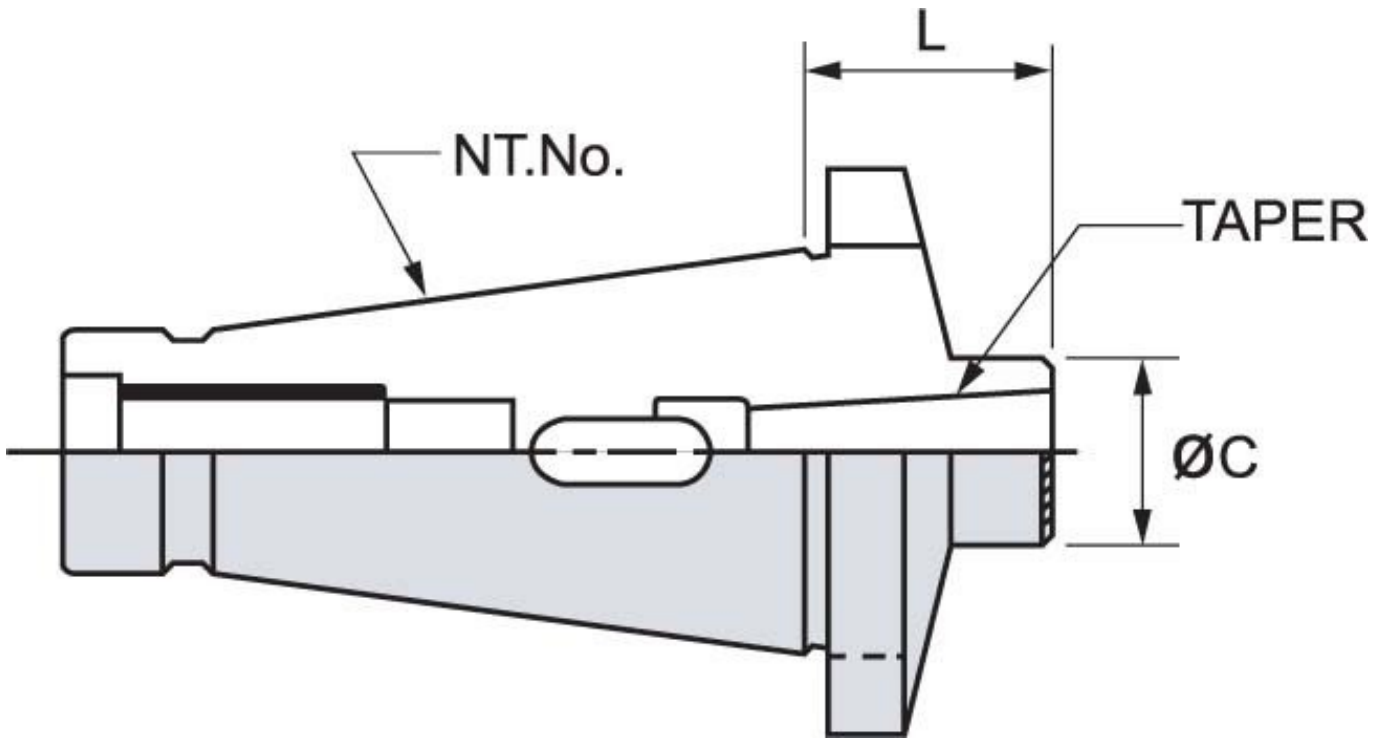

ORDER CODE	M1724
MODEL	NT40-NT30
Outer Taper	NT40
Inside Taper	NT30
Drawbar Thread (mm / inch)	~
L (mm)	15
C (mm)	~
Nett Weight (kg)	1.00