

**TOOLMASTER**



**NT30-MT2-50 Milling Adaptor**



**TOOLMASTER NT30-MT2-50 Milling Adaptor**

**Description**

Precision ground and hardened.  
Morse taper adaptors are used to adapt a Morse taper tool or cutter to any spindle taper

**Specifications**

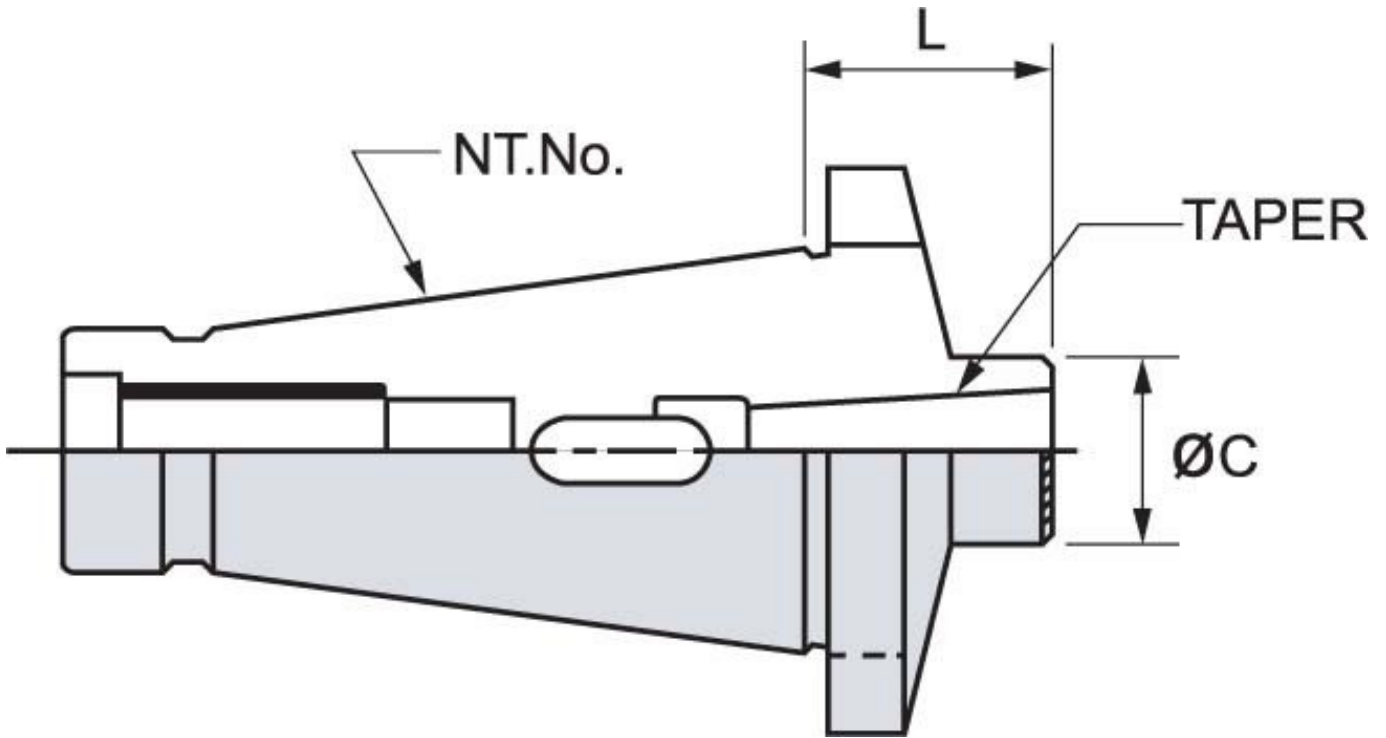

<b>ORDER CODE</b>	M165
<b>MODEL</b>	NT30-MT2-50
<b>Outer Taper</b>	NT30
<b>Inside Taper</b>	MT2
<b>Drawbar Thread (mm / inch)</b>	12mm
<b>L (mm)</b>	50
<b>C (mm)</b>	32
<b>Nett Weight (kg)</b>	0.80