

TOOLMASTER S32T-MWLNR-08

Right Hand Boring Bar

Ø32mm



TOOLMASTER Right Hand Boring Bar S32T-MWLN-08



Front View



Side View



Locking Tool

Description

NOTE: Inserts NOT included with tool holders.

Use insert WNMG 08 (code L053)

Features

- Negative rake boring bar suitable for turning and facing
- Suitable for rapid metal removal

Specifications

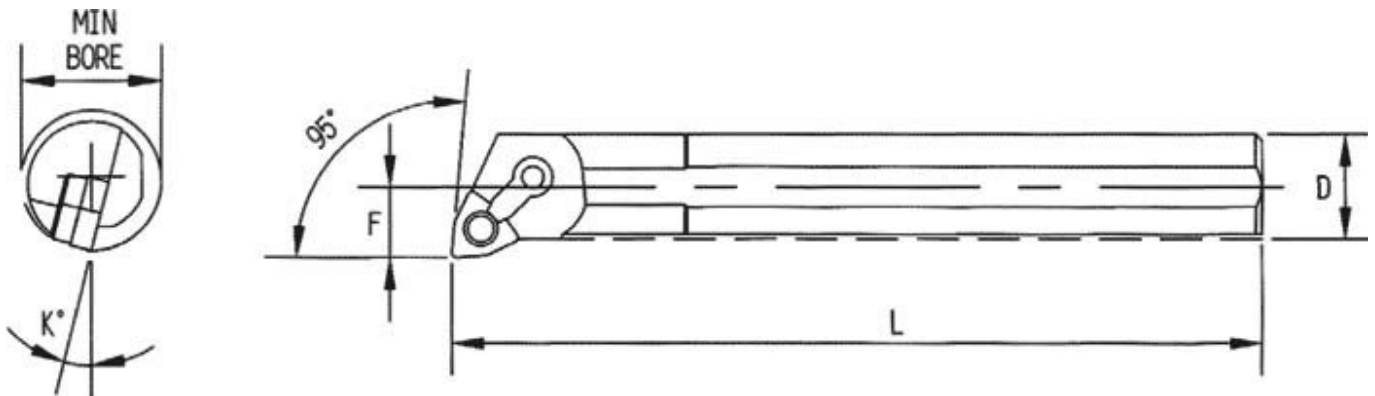

ORDER CODE	L417
Part Number - Style	MWLN
Size (mm)	32
Hand Type	RIGHT
B = Minimum Bore (mm)	40
D (mm)	32
F (mm)	22
L (mm)	300
K (deg)	14°
Minimum Bore (mm)	38