

TOOLMASTER S25T-MWLNR-08

Right Hand Boring Bar

Ø25mm



TOOLMASTER Right Hand Boring Bar S25T-MWLN-08



Full View



Side View



Locking Tool

Description

NOTE: Inserts NOT included with tool holders.

Use insert WNMG 08 (code L053)

Features

- Negative rake boring bar suitable for turning and facing
- Suitable for rapid metal removal

Specifications

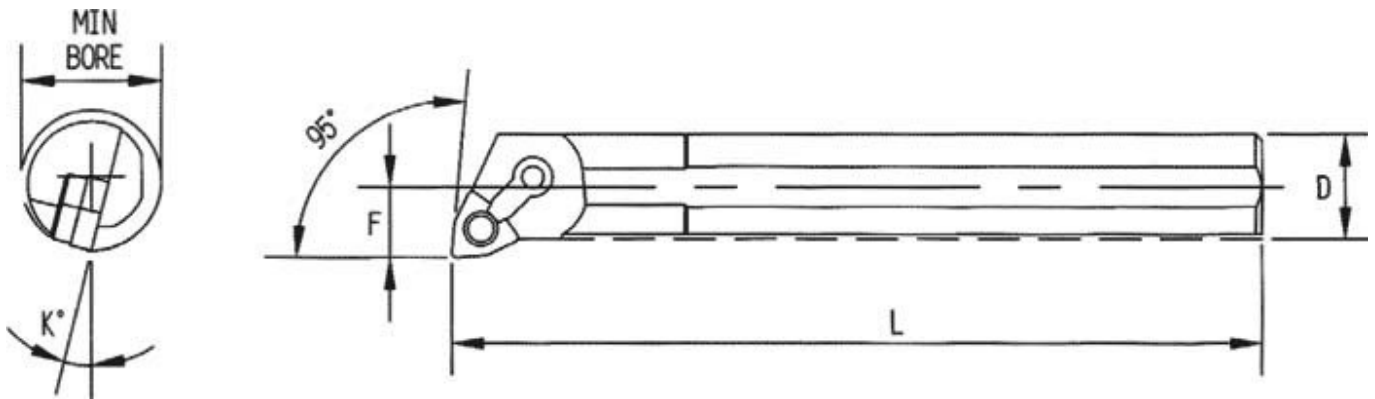

ORDER CODE	L416
Part Number - Style	MWLN
Size (mm)	25
Hand Type	RIGHT
B = Minimum Bore (mm)	32
D (mm)	25
F (mm)	17
L (mm)	300
K (deg)	14°
Minimum Bore (mm)	29.5