

**TOOLMASTER S20T-MWLNR-08**

**Right Hand Boring Bar**

**Ø20mm**



**TOOLMASTER Right Hand Boring Bar S20T-MWLN-08**



Full View



Side View



Locking Tool

**Description**

NOTE: Inserts NOT included with tool holders.

Use insert WNMG 08 (code L053)

**Features**

- Negative rake boring bar suitable for turning and facing
- Suitable for rapid metal removal

**Specifications**

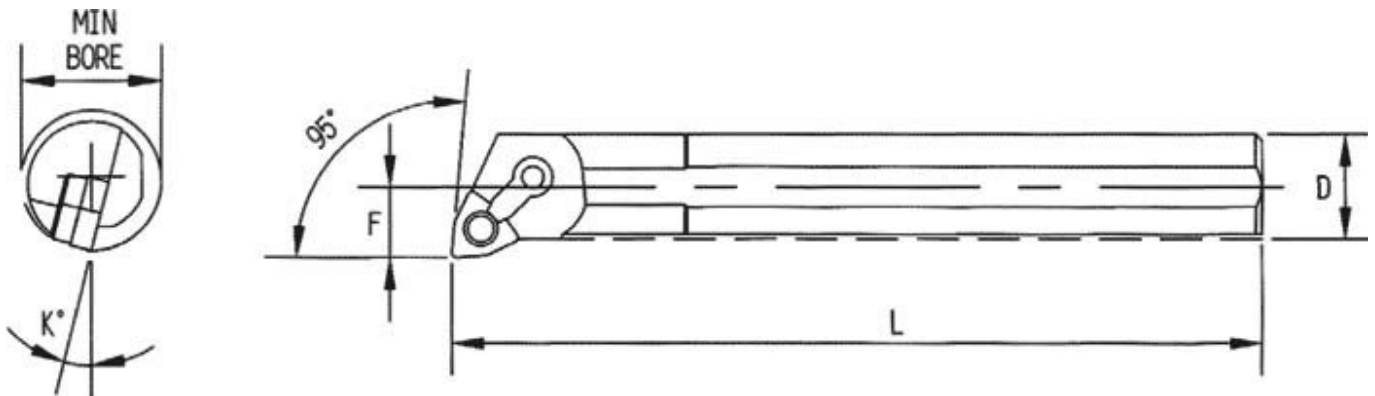

<b>ORDER CODE</b>	L415
<b>Part Number - Style</b>	MWLN
<b>Size (mm)</b>	20
<b>Hand Type</b>	RIGHT
<b>B = Minimum Bore (mm)</b>	25
<b>D (mm)</b>	20
<b>F (mm)</b>	13
<b>L (mm)</b>	250
<b>K (deg)</b>	17°
<b>Minimum Bore (mm)</b>	23