

TOOLMASTER QA-150

Quick Change Toolpost

150 - 170mm Lathe Centre Height



TOOLMASTER Quick Change Toolpost QA-150**Description**

Manufactured in Taiwan

Manufactured from carbonized and hardened steel.
Italian design style.

Features

- All bearing surfaces are precision ground to ensure rigidity
- Handy lathe accessory for tool rooms and general engineering shops
- Ease of operation cuts set-up time by 90%
- No shims are required to adjust tools to correct centre height
- Easily fitted to most centre lathes
- Please Note: Some machining required to suit your lathe

Includes

- 3 x Square Tool Holders - for 16mm tools
- 1 x Vee Tool Holders - for boring bars

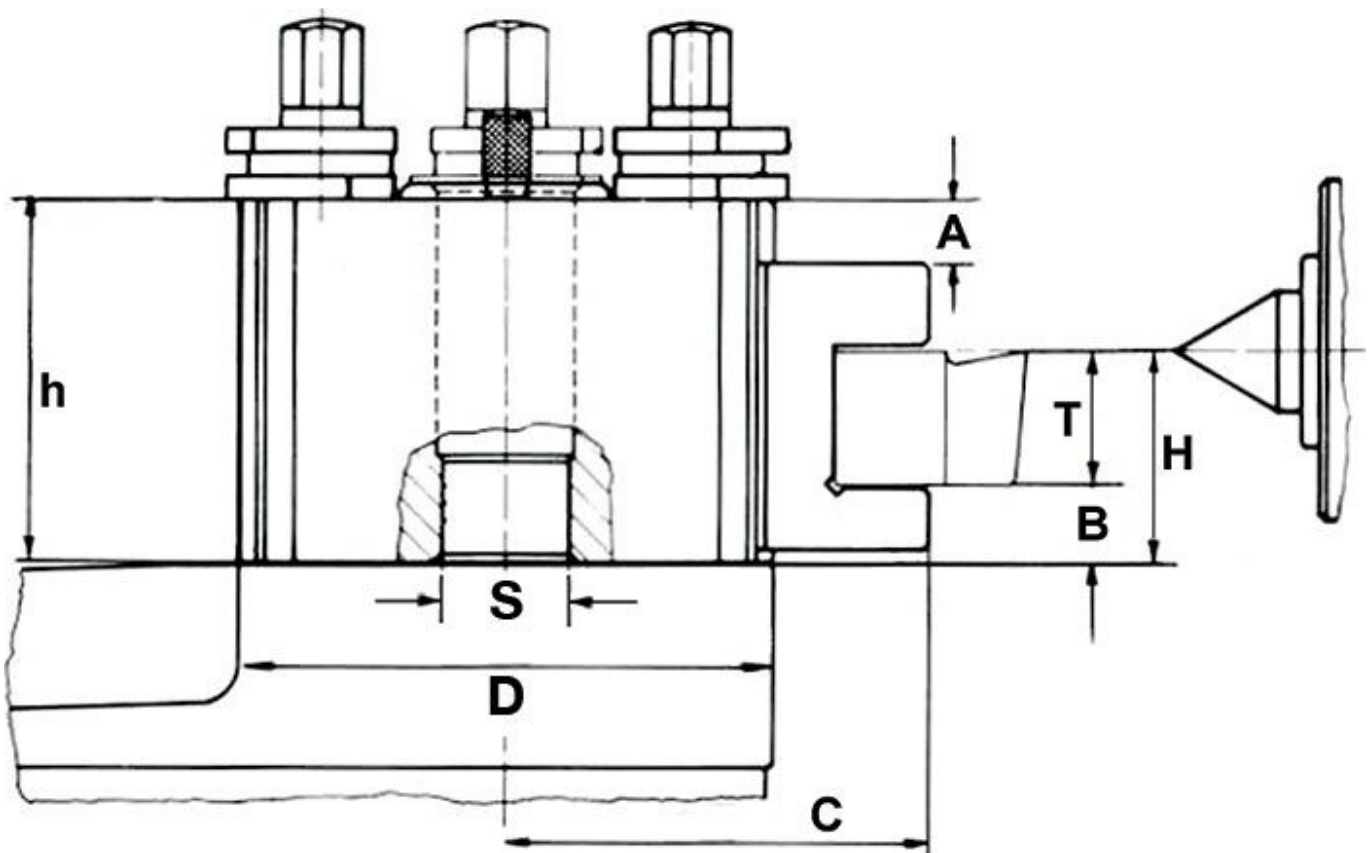
Specifications**ORDER CODE**

L295

TOOLMASTER Quick Change Toolpost QA-150

MODEL	QA-150
Lathe Centre Height (mm)	150 - 170
Lathe Swing (mm)	300 - 340
A (mm)	15
B (mm)	20
C (mm)	60
D (mm)	74
E (mm)	~
H (mm)	28 - 41
h (mm)	60
S (mm)	24
T (mm)	16
Y (mm)	~
Number of Sides (No.)	2
Number of Holders (No.)	4
Nett Weight (kg)	6.2