

**TOOLMASTER QA-100**

**Quick Change Toolpost**

**75 - 115mm Lathe Centre Height**



## TOOLMASTER Quick Change Toolpost QA-100

### Description

Manufactured from carbonized and hardened steel.  
 Suitable for 75-110mm centre Height Lathes

### Features

- All bearing surfaces are precision ground to ensure rigidity
- Handy lathe accessory for tool rooms and general engineering shops
- Ease of operation cuts set-up time by 90%
- No shims are required to adjust tools to correct centre height
- Easily fitted to most small centre lathes
- Please Note:
- Some machining maybe required to suit your lathe
- 'S' dimension represents bush OD & ID

### Includes

- 3 x Square Tool Holders - (14mm opening) for 10mm or 12mm tools
- 1 x Boring Bar Holder - with Vee
- 1 x Socket Wrench & Allen keys
- 20mm to 10mm Mounting bush

### Specifications

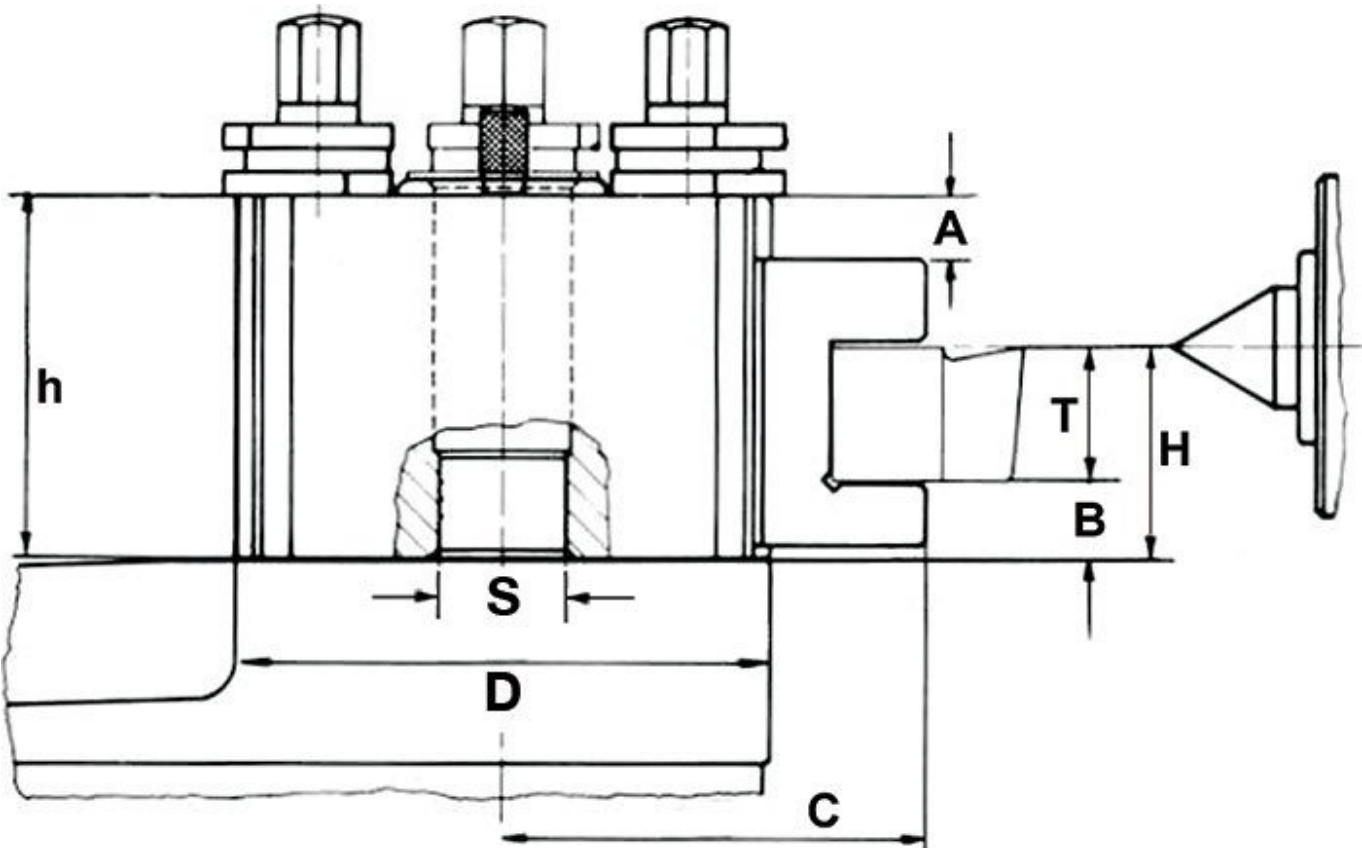

**TOOLMASTER Quick Change Toolpost QA-100**

**ORDER CODE**

**TOOLMASTER Quick Change Toolpost QA-100**

L280

<b>MODEL</b>	QA-100
<b>Lathe Centre Height (mm)</b>	75 - 115
<b>Lathe Swing (mm)</b>	150 - 230
<b>A (mm)</b>	12
<b>B (mm)</b>	6
<b>C (mm)</b>	50
<b>D (mm)</b>	58
<b>E (mm)</b>	~
<b>H (mm)</b>	18 - 30
<b>h (mm)</b>	40
<b>S (mm)</b>	20 - 10
<b>T (mm)</b>	12
<b>Y (mm)</b>	~
<b>Number of Sides (No.)</b>	2
<b>Number of Holders (No.)</b>	4
<b>Nett Weight (kg)</b>	2.5