

TOOLMASTER WTJNL-2525-M16

Left Hand Turning Tool Holder

25mm Tool Height



TOOLMASTER Left Hand Turning Tool Holder WTJNL-2525-M16



Side View



Top View

Description

Quality Tipped Tool Holders ISO Standard to suit Tungsten Carbide Indexable Insert Tips.

NOTE: Inserts not included with tool holders

Use insert TNMG 160408 (L064)

Features

- Negative rake turning tool holder with 93° approach angle
- Suitable for rapid metal removal
- Left hand tool holder suitable for facing operations

Specifications

TOOLMASTER Left Hand Turning Tool Holder WTJNL-2525-M16

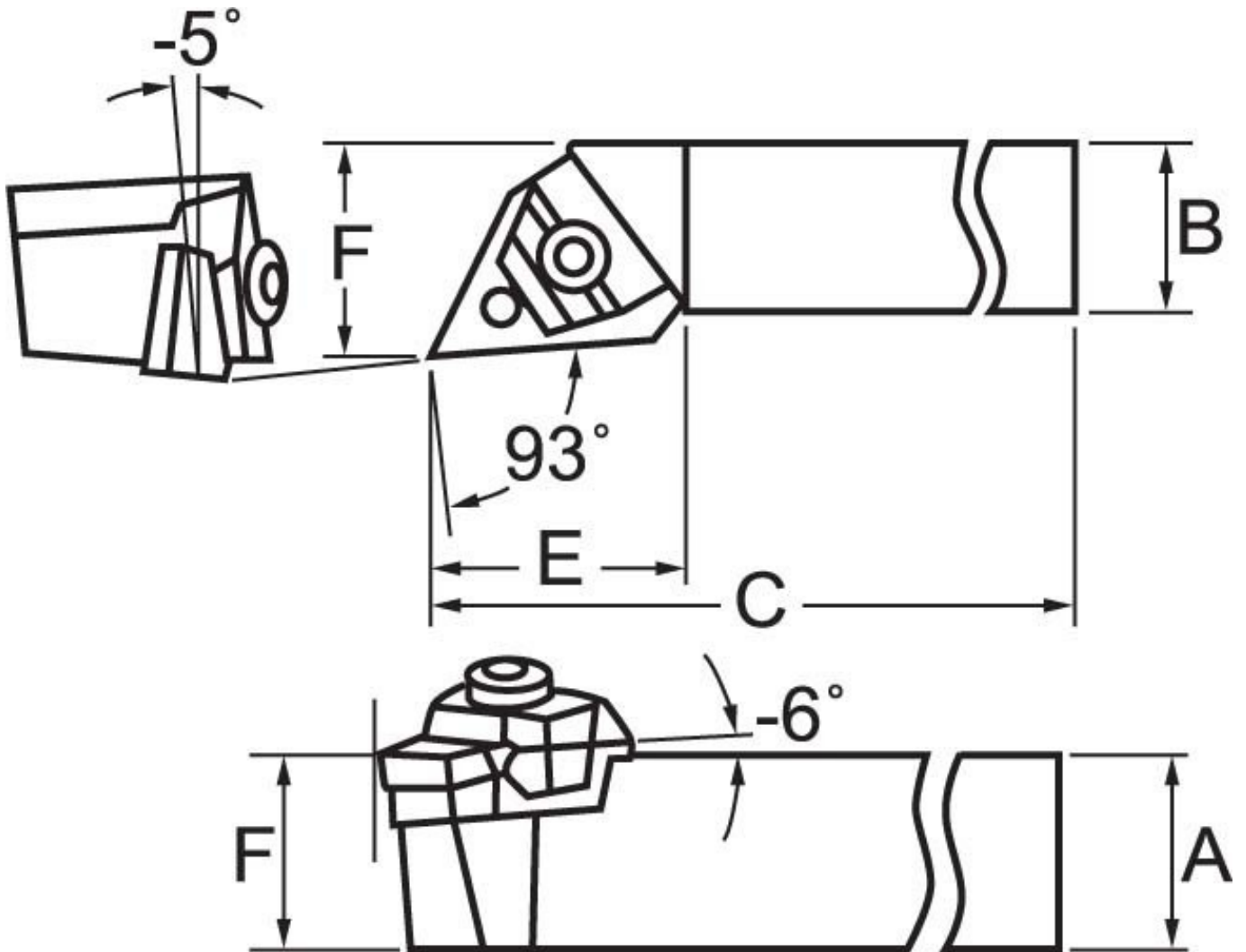

TOOLMASTER Left Hand Turning Tool Holder WTJNL-2525-M16

ORDER CODE

TOOLMASTER Left Hand Turning Tool Holder WTJNL-2525-M16

L049

Part Number - Style	WTJN
Tool Height Size (mm)	25
Clamping Method of Insert	~
Category	~
Connection style	~
Back End Size	~
Application	~
Hand Type	Left
Holder Style	~
Clearance Angle	~
Insert Type	TNMG16
A (H) (mm)	25
B (mm)	25
C (LF) (mm)	150
LH (mm)	~
F (WF) (mm)	25
E (mm)	32