

**TOOLMASTER WTJNR-2525-M16**

**Right Hand Turning Tool Holder**

**25mm Tool Height**



**TOOLMASTER Right Hand Turning Tool Holder WTJNR-2525-M16**

**Description**

Quality Tipped Tool Holders ISO Standard to suit Tungsten Carbide Indexable Insert Tips.

NOTE: Inserts not included with tool holders

Use insert TNMG 160408 (L064)

**Features**

- Negative rake turning tool holder with 93° approach angle
- Suitable for rapid metal removal
- Right hand tool holder suitable for turning towards the chuck

**Specifications**

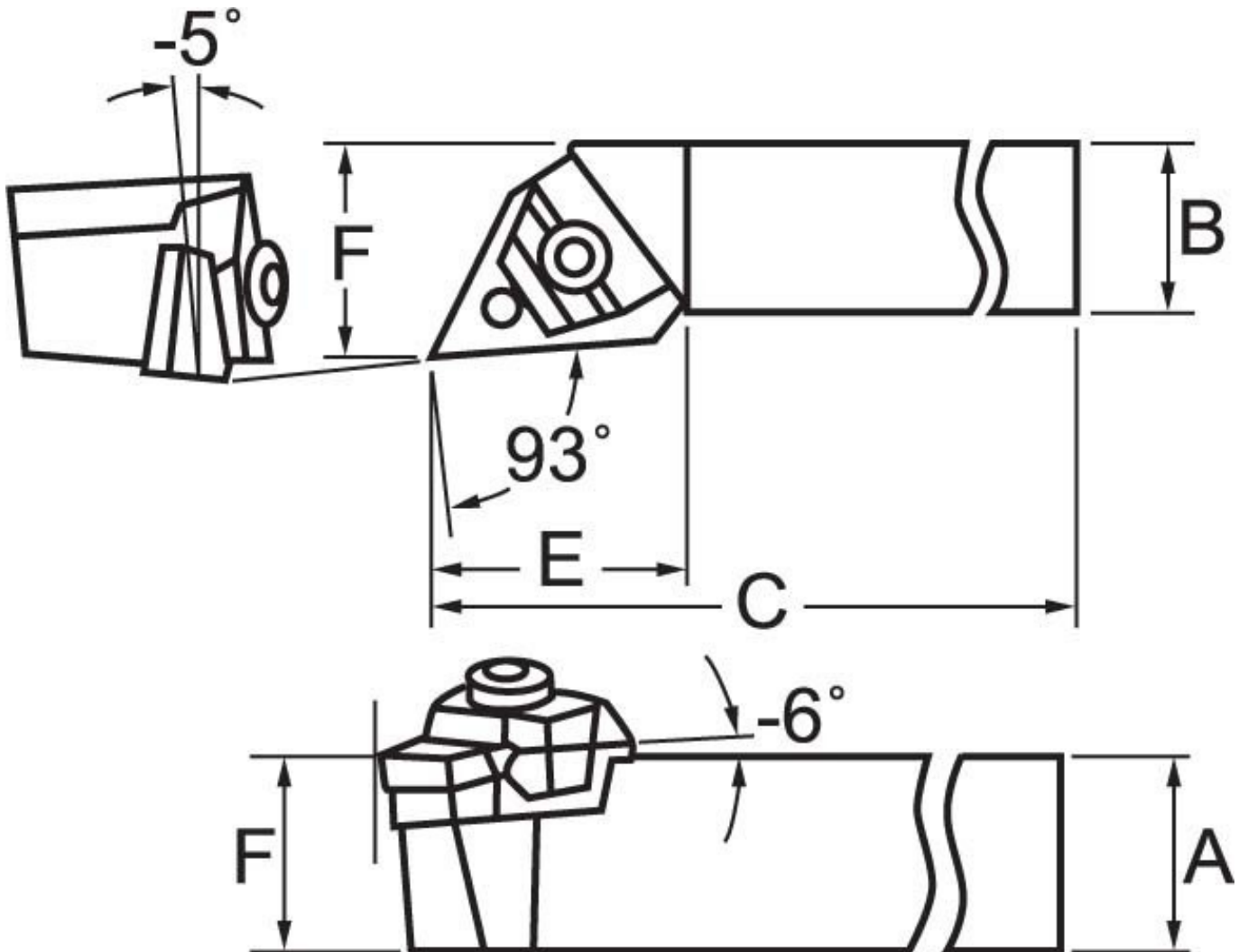

<b>ORDER CODE</b>	L048
<b>Part Number - Style</b>	WTJN
<b>Tool Height Size (mm)</b>	25

**TOOLMASTER Right Hand Turning Tool Holder WTJNR-2525-M16**

<b>Clamping Method of Insert</b>	~
<b>Category</b>	~
<b>Connection style</b>	~
<b>Back End Size</b>	~
<b>Application</b>	~
<b>Hand Type</b>	Right
<b>Holder Style</b>	~
<b>Clearance Angle</b>	~
<b>Insert Type</b>	TNMG16
<b>A (H) (mm)</b>	25
<b>B (mm)</b>	25
<b>C (LF) (mm)</b>	150
<b>LH (mm)</b>	~
<b>F (WF) (mm)</b>	25
<b>E (mm)</b>	32