

TOOLMASTER MTJNR-1616-H16

Right Hand Turning Tool Holder

16mm Tool Height



TOOLMASTER Right Hand Turning Tool Holder MTJNR-1616-H16

Description

Quality Tipped Tool Holders ISO Standard to suit Tungsten Carbide Indexable Insert Tips.

NOTE: Inserts not included with tool holders

Use insert TNMG 160408 (L064)

Features

- Negative rake turning tool holder with 93° approach angle
- Suitable for rapid metal removal
- Right hand tool holder suitable for turning towards the chuck

Specifications

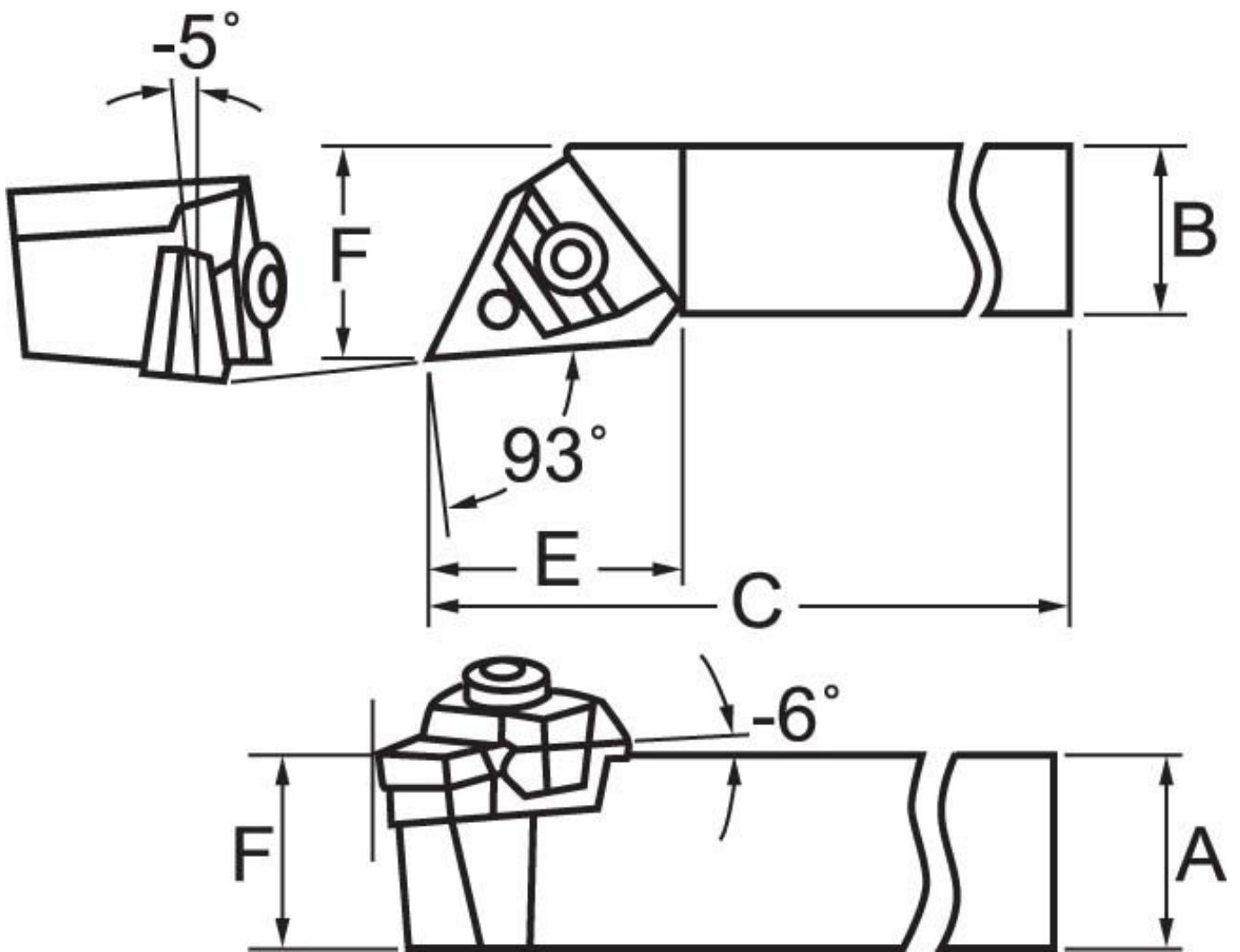

ORDER CODE	L044
Part Number - Style	MTJN
Tool Height Size (mm)	16

TOOLMASTER Right Hand Turning Tool Holder MTJNR-1616-H16

Clamping Method of Insert	~
Category	~
Connection style	~
Back End Size	~
Application	~
Hand Type	Right
Holder Style	~
Clearance Angle	~
Insert Type	TNMG16
A (H) (mm)	16
B (mm)	16
C (LF) (mm)	100
LH (mm)	~
F (WF) (mm)	20
E (mm)	30