



**TOOLMASTER S25T-MTUN-16A**

**Right Hand Boring Bar**

**Ø25mm**



**TOOLMASTER Right Hand Boring Bar S25T-MTUN-16A**



Full View

**Description**

NOTE: Inserts NOT included with tool holders.

Use insert TNMG 160408 16mm (L064)

**Features**

- Negative rake boring bar with 93° approach angle
- Suitable for rapid metal removal

**Specifications**

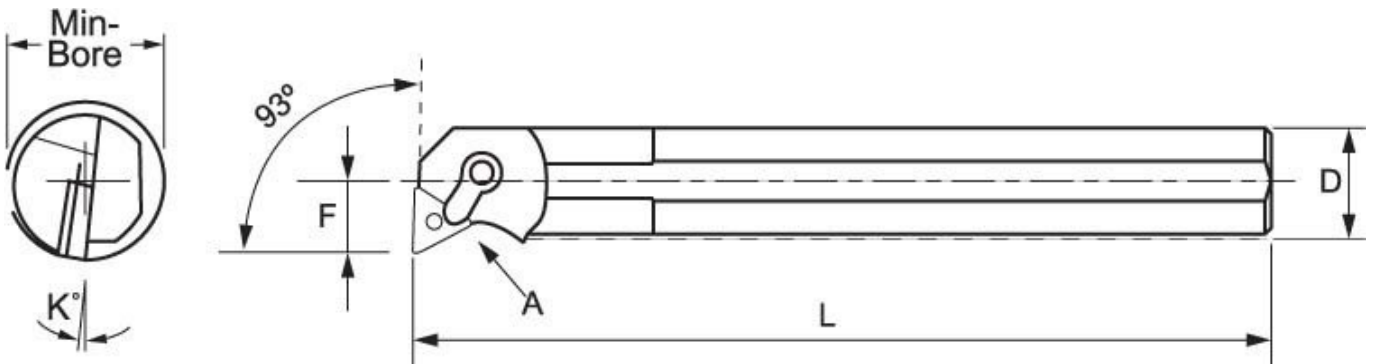

<b>ORDER CODE</b>	L024
<b>Part Number - Style</b>	MTUN
<b>Size (mm)</b>	25
<b>Hand Type</b>	RIGHT
<b>B = Minimum Bore (mm)</b>	32
<b>D (mm)</b>	25
<b>F (mm)</b>	17
<b>L (mm)</b>	300
<b>K (deg)</b>	12°
<b>Minimum Bore (mm)</b>	29.5