

TOOLMASTER S20T-MTUN-16

Right Hand Boring Bar

Ø20mm



TOOLMASTER Right Hand Boring Bar S20T-MTUN-16



Front View



Side View



Locking Tool

Description

NOTE: Inserts NOT included with tool holders.

Use insert TNMG 160408 16mm (L064)

Features

- Negative rake boring bar with 93° approach angle
- Suitable for rapid metal removal

Specifications

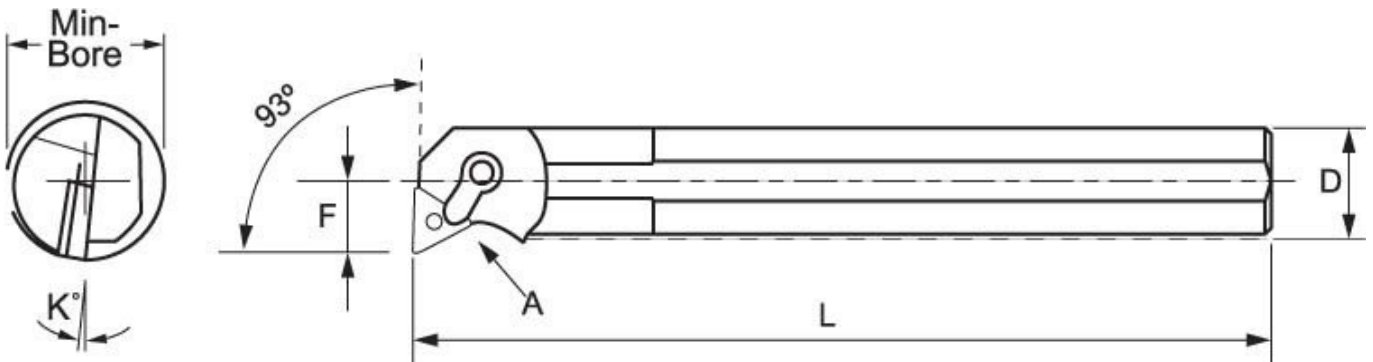

ORDER CODE	L0235
Part Number - Style	MTUN
Size (mm)	20
Hand Type	RIGHT
B = Minimum Bore (mm)	25
D (mm)	20
F (mm)	13
L (mm)	300
K (deg)	17°
Minimum Bore (mm)	25.5