

TOOLMASTER S16Q-STFCR-11

Right Hand Boring Bar

Ø16mm



TOOLMASTER Right Hand Boring Bar S16Q-STFCR-11



Full View

Description

NOTE: Inserts NOT included with tool holders.

Use insert TCMT 110204 (L062)

Features

- Positive rake boring bar with 90° approach angle
- Suitable for low powered machines

Specifications

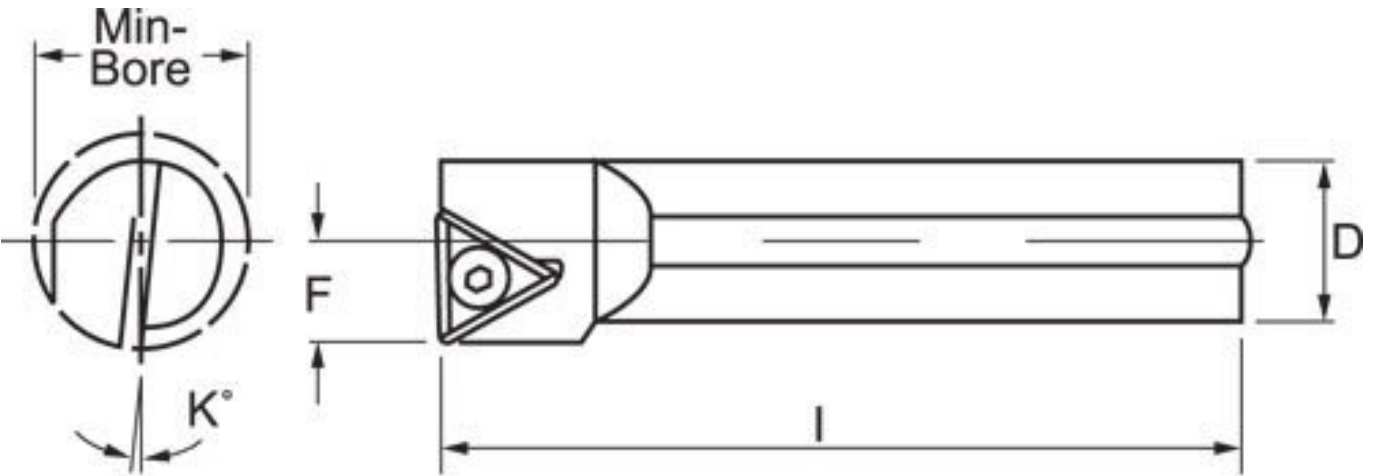

ORDER CODE	L022
Part Number - Style	STFC
Size (mm)	16
Hand Type	RIGHT
B = Minimum Bore (mm)	20
D (mm)	16
F (mm)	11
L (mm)	180
K (deg)	6°
Minimum Bore (mm)	19