



TOOLMASTER S10K-SCLCR-06-12

Right Hand Boring Bar

Ø10mm



TOOLMASTER Right Hand Boring Bar S10K-SCLCR-06-12



Full View



Side View



Locking Tool

Description

NOTE: Inserts NOT included with tool holders.

Use insert CCMT 60204 (L060)

Features

- Positive rake boring with 95° approach angle
- Suitable for low powered machines
- Right hand tool holder suitable for turning towards the chuck

Specifications

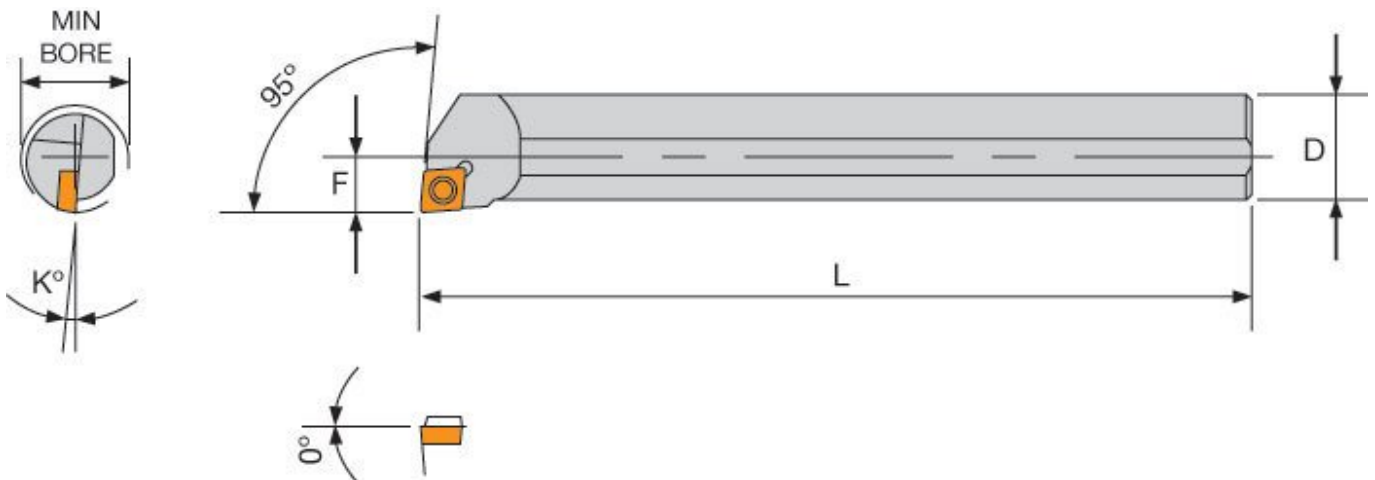

ORDER CODE	L0201
Part Number - Style	SCLC
Size (mm)	10
Hand Type	RIGHT
B = Minimum Bore (mm)	12
D (mm)	10
F (mm)	6
L (mm)	125

TOOLMASTER Right Hand Boring Bar S10K-SCLCR-06-12

K (deg)	12°
Minimum Bore (mm)	12