

TOOLMASTER S08K-SCLCR-06-10

Right Hand Boring Bar

Ø8mm



TOOLMASTER Right Hand Boring Bar S08K-SCLCR-06-10



Full View



Side View

Description

NOTE: Inserts NOT included with tool holders.

Use insert CCMT 60204 (L060)

Features

- Positive rake boring with 95° approach angle
- Suitable for low powered machines
- Right hand tool holder suitable for turning towards the chuck

Specifications

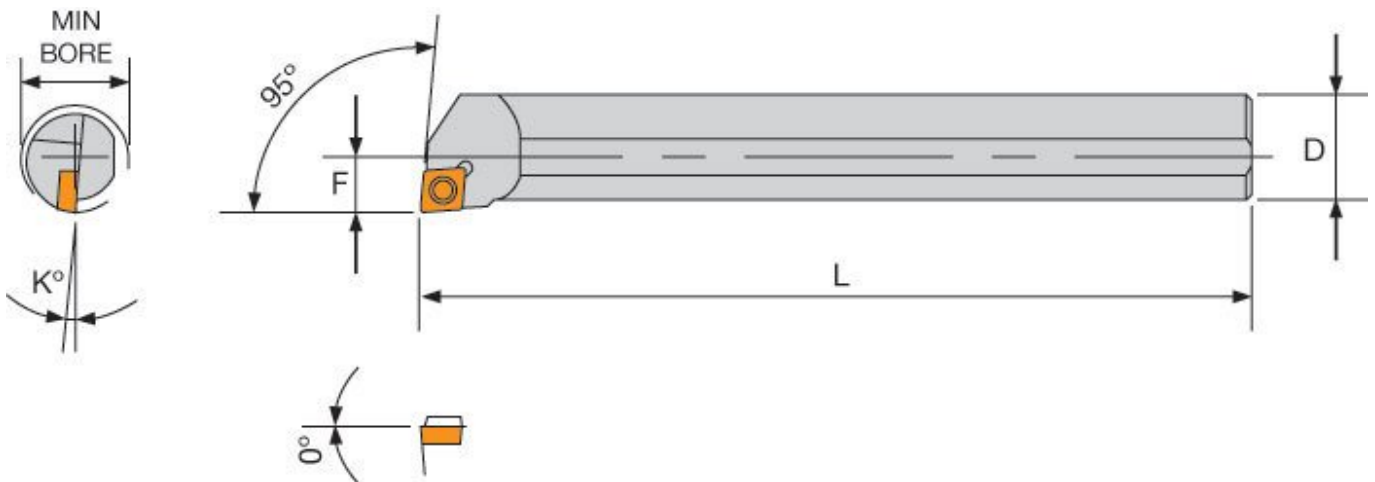

ORDER CODE	L020
Part Number - Style	SCLC
Size (mm)	8
Hand Type	RIGHT
B = Minimum Bore (mm)	10
D (mm)	8
F (mm)	5
L (mm)	125

TOOLMASTER Right Hand Boring Bar S08K-SCLCR-06-10

K (deg)	13°
Minimum Bore (mm)	10