

HAFCO MG-1



Mill-Drill Safety Guard



HAFCO Mill-Drill Safety Guard MG-1



Front View



Side View



Right View



Rear View

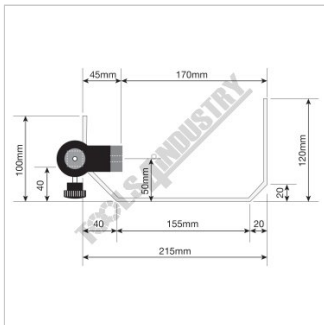

Top View Dimensions

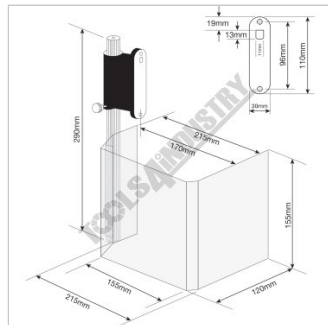

Dimensions

Features

- Perspex guard (LxWxH) 215 x 120 x 155mm
- Aluminium extrusion and plastic housing has micro switch
- Retro fits to most Mill / drilling machines
- Safety chuck guard comes complete with mounting bracket with built-in micro switch and 0.5 Metre of wiring to be connected to the electrical cabinet
- Just fasten the mounting bracket to the side of mill/drill head
- Micro switch recommended for 12V or 24V
- Installation is required by a licensed electrician

Specifications

ORDER CODE	G601
MODEL	MG-1
Suits Mill Heads	Mill / Drill
Same Guard on Model	~