

## HAFCO-METALMASTER DMF-44



**Pedestal Mill Drill - Geared & Tilting Head**

**Table Travel: (X) - 480mm (Y) - 200mm (Z) - 850mm**



## HAFCO-METALMASTER Pedestal Mill Drill - Geared & Tilting Head DMF-44



Tilt Head Full View



Left View



Rear Left View



Rear Right View



Milling Head



Mill Head Close Up



Control Panel with Tapping Function



Geared Spindle Speed Dials



Adjustable Drilling Depth Stop



Quill Lock Lever

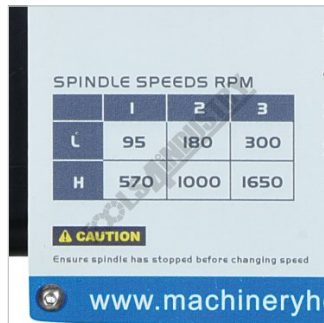

6 Drilling Speeds 95 ~ 165rpm



Interlocked Spindle Safety Guard



Rack & Pinion Wind Up Drill Head



Rack & Pinion Wind Up Table



Quill Handle



Quill Micro Fine Feed Dial

**HAFCO-METALMASTER Pedestal Mill Drill - Geared & Tilting Head DMF-44**



Heavy Duty Motor



Draw Bar For Milling



Table With Coolant Return Hose



Flexible Coolant Hose

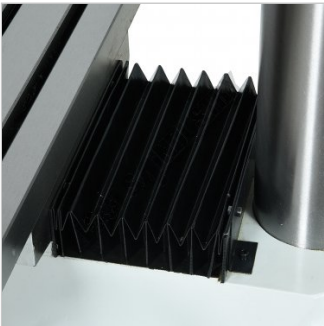

Concertina Rear Slide-Way Cover



Tilting Head  $\pm 90^\circ$



Head Tilted To  $45^\circ$



Main Isolation Switch



Table Cross Feed Handle



Table Longitudinal Handle

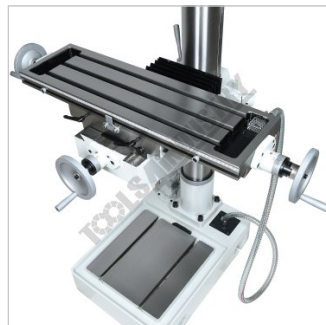

T Slotted Work Table



Work Table with Length Stops



T Slotted Base



Coolant Pump System



Coolant Pump



Milling Cutter



## HAFCO-METALMASTER Pedestal Mill Drill - Geared & Tilting Head DMF-44

### Includes

- Interlocked spindle safety guard
- Face milling cutter with inserts
- 13mm keyed drill chuck and arbor
- Chuck key to suit
- MT3 to MT2 drill sleeve adapter
- Drill drift tool to remove drill chuck or taper shank drills
- M12 x 1.75mm drawbar
- 1/2" x 12TPI drawbar

### Specifications

<b>ORDER CODE</b>	D185
<b>MODEL</b>	DMF-44
<b>Digital Readout</b>	Optional
<b>Type</b>	Vertical
<b>Table Size (mm)</b>	730 x 210
<b>Column Type</b>	Ø125mm
<b>Spindle Taper - Vertical</b>	3MT
<b>Spindle Taper - Horizontal</b>	~
<b>Longitudinal Travel (X-Axis) (mm)</b>	480
<b>Cross Travel (Y-Axis) (mm)</b>	200
<b>Vertical Travel (Z-Axis) (mm)</b>	850
<b>Type of Slides</b>	Dovetail
<b>Ram Travel (mm)</b>	~
<b>Spindle to Table (mm)</b>	630
<b>Spindle to Base</b>	~
<b>Spindle Travel / Diameter (mm)</b>	120 / 75
<b>Throat Depth (max.) (mm)</b>	280
<b>Tilting Head (Left ~ Right)</b>	±90°
<b>Tilting Head (Forward ~ Back)</b>	Fixed
<b>Drilling Capacity (mm)</b>	31.5
<b>End Milling Capacity (mm)</b>	28
<b>Face Milling Capacity (mm)</b>	80
<b>Power Feed - Quill (mm/rev)</b>	~
<b>Power Feed - Longitudinal (X-Axis) (mm/min)</b>	Optional
<b>Power Feed - Cross (Y-Axis) (mm/min)</b>	~
<b>Power Feed - Vertical (Z-Axis) (mm/min)</b>	~
<b>Table T-Slot Size (inch / mm)</b>	14
<b>Work Table Load Capacity (kg)</b>	55
<b>Spindle Speeds Vertical (No./ rpm)</b>	6 (95 - 1650)
<b>Spindle Speeds Horizontal (No./ rpm)</b>	~
<b>Spindle Speeds - Universal Head</b>	~
<b>Motor Power - Vertical Spindle (kW / hp)</b>	1.5 / 2
<b>Motor Power - Horizontal Spindle (kW / hp)</b>	~
<b>Motor Power - Universal Head</b>	~
<b>Voltage / Amperage (V / amp)</b>	240 / 10

**HAFCO-METALMASTER Pedestal Mill Drill - Geared & Tilting Head DMF-44**

---

<b>Nett Weight (kg)</b>	390
-------------------------	-----

---