

**TOOLMASTER K12-160**

**4 Jaw Self Centring Lathe Chuck**

**Ø160mm**



**TOOLMASTER 4 Jaw Self Centring Lathe Chuck K12-160**



Back Plate Mount



Included Accessories



Front View

**Description**

160mm 4-JAW SELF-CENTRING LATHE CHUCK  
Manufactured from cast iron.  
Available only in back mount.

**Includes**

- 1 x set of outside hard jaws
- 1 x set of inside hard jaws
- 1 x key
- 1 x set of mounting screws

**Specifications**

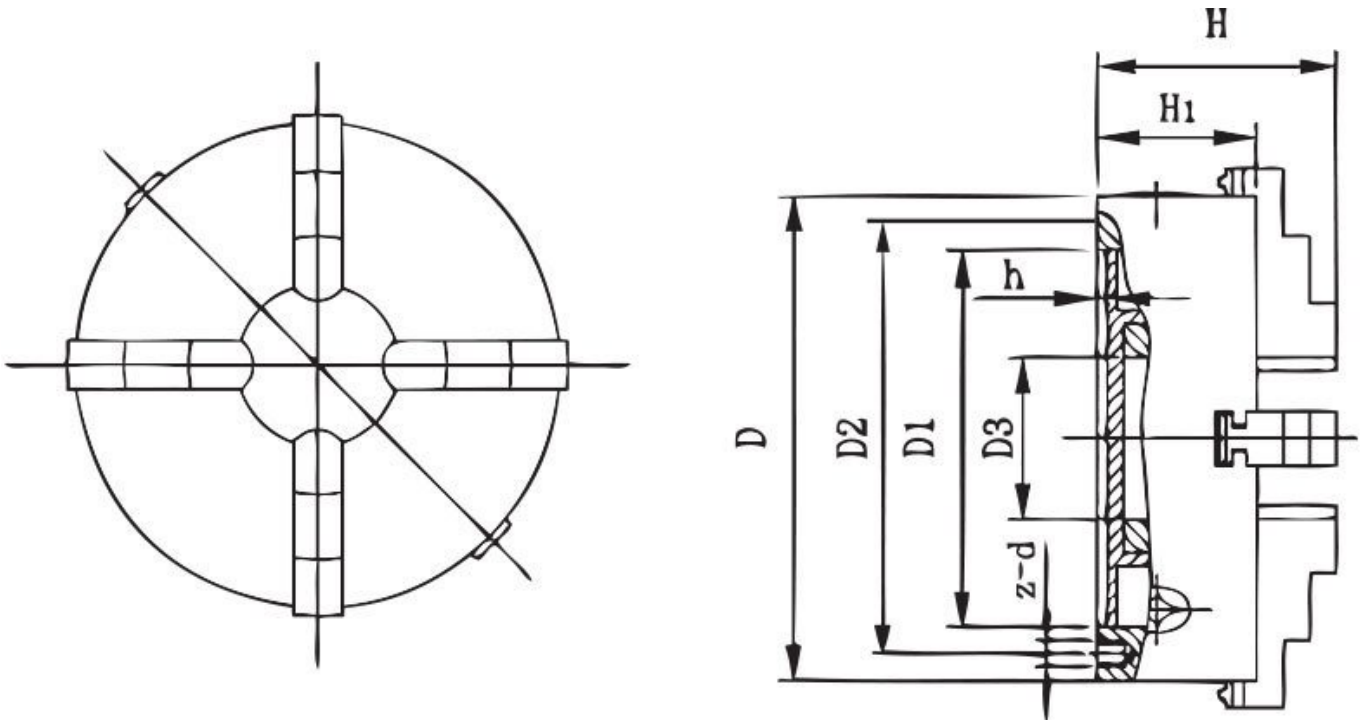

**TOOLMASTER 4 Jaw Self Centring Lathe Chuck K12-160**

**ORDER CODE**

**TOOLMASTER 4 Jaw Self Centring Lathe Chuck K12-160**

C723

<b>Size (mm)</b>	Ø160
<b>Outside Jaw (mm)</b>	3 - 55
<b>Inside Jaw (mm)</b>	55 - 145
<b>Speed (rpm)</b>	2500
<b>D1 (mm)</b>	130
<b>D2 (mm)</b>	142
<b>D3 (bore) (mm)</b>	45
<b>H (mm)</b>	95
<b>H1 (mm)</b>	65
<b>h (mm)</b>	5
<b>z-d (mm)</b>	3-M8
<b>Nett Weight (kg)</b>	8.7