

TOOLMASTER K11-200/D14

3 Jaw Self Centring Lathe Chuck

Ø200mm



TOOLMASTER 3 Jaw Self Centring Lathe Chuck K11-200/D14



Camlock Mount



Included Accessories



Front View

Description

K11 SERIES Cast Iron Body
Standard GB/T 4346.2-2002

Features

- World-class and industry leader in the manual lathe chuck field with over 30 years of manufacturing
- ToolMaster quality assurance and accuracy testing ensure standards remain high. ToolMaster is ISO 9001-2000 approved
- Each chuck is supplied with a set of inside and outside jaws and a chuck key

Includes

- Outside jaws
- Inside jaws
- Chuck key

Specifications

TOOLMASTER 3 Jaw Self Centring Lathe Chuck K11-200/D14

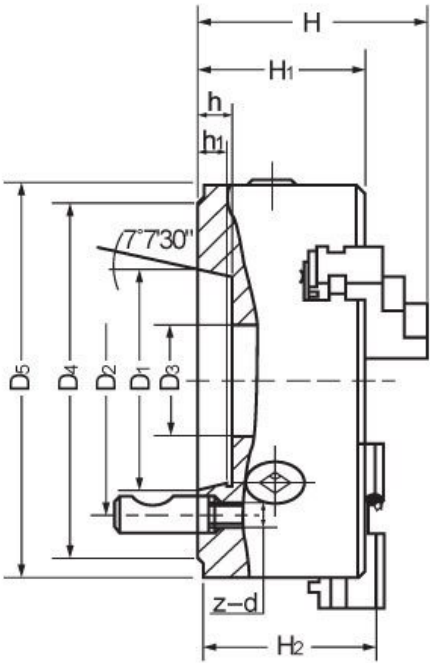

CAMLOCK

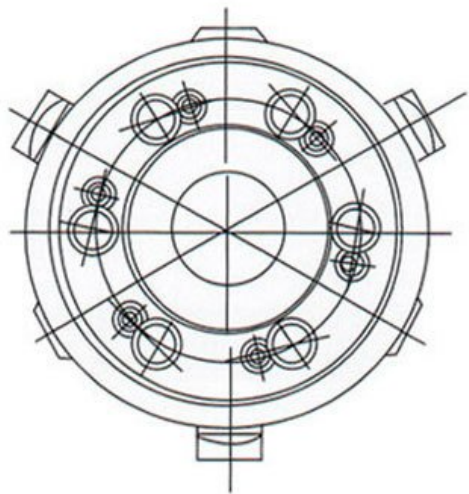

TOOLMASTER 3 Jaw Self Centring Lathe Chuck K11-200/D14

ORDER CODE

TOOLMASTER 3 Jaw Self Centring Lathe Chuck K11-200/D14

C262

Chuck Size (mm)	Ø200
Camlock	D1-4
Outside Jaw (mm)	4 - 85
Inside Jaw (mm)	65 - 200
Speed (rpm)	2000
D1 (mm)	63.52
D2 (mm)	180
D3 (mm)	50
H (mm)	109
H1 (mm)	75
h (mm)	5
Nett Weight (kg)	18