

**GARRICK LIFTING GLHLL150**



**Lever Block**

**1.5 Tonne x 1.5 Metre**



## GARRICK LIFTING Lever Block GLHLL150

### Features

- Robust all steel construction
- Super strength alloy load chain - 1.5T, 3T & 6T models fitted with grade 100 chain
- All hooks fitted with spring safety latch
- Durable stainless steel labels
- Test Certificate and Instruction Manual supplied with every Lever Hoist
- Complies with ASNZS1418.2
- Meets or exceeds other International Standards such as GS, CE & ANSI

### Specifications

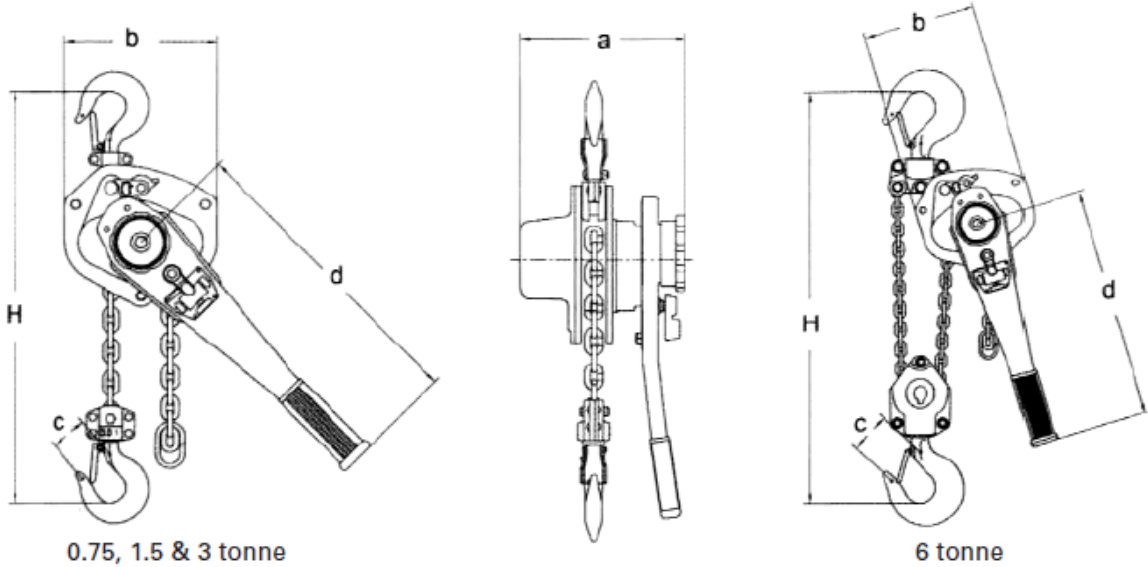

Capacity (tonnes)	Model No.	No. of Falls	Chain dia. (mm)	Load Chain Grade	Pull of Rated Load (kN)	Net Wt. with 1.5m Lift (kg)	Extra Wt. per m (kg)	Dimensions (mm)				
								a	b	c	d	H
0.75	GLH075	1	6.3	80	15	6.9	0.85	148	128	37	256	295
1.5	GLH150	1	7.1	100	18	9.7	1.11	163	148	47	368	335
3	GLH300	1	9.0	100	38	16.3	1.77	191	181	62	368	405
6	GLH600	2	9.0	100	39	26.7	3.55	191	244	78	368	550

**GARRICK LIFTING Lever Block GLHLL150**

**ORDER CODE**

**GARRICK LIFTING Lever Block GLHLL150**

C174

<b>MODEL</b>	GLHLL150
<b>Lift Capacity (kg / Tonne)</b>	1500 / 1.5
<b>Lift Height (Metre)</b>	1.5
<b>Weight (kg)</b>	~